

Instruction

Manual



GTCR

Wheel Type Offset Disc Harrow
Remote Control - Heavy Duty

GTCR-CR

Wheel Type Offset Disc Harrow
Remote Control - Heavy Duty

 **BALDAN**

INTRODUCTION

We thank you for the preference and congratulate your excellent choice in acquiring an implement of outstanding quality, manufactured in accordance with the advanced technology of **BALDAN IMPLEMENTOS AGRÍCOLAS S/A**.

This manual will assist you, in proceeds necessities, since when you bought until the operational proceeds application, security and maintenance.

The **BALDAN** guarantees that deliver this implement to the dealer, working properly, and in perfect conditions.

The dealers it's under the responsibility to keep the protection and conservation while keep the implement in your stock, and than, to assembly, tighten, lubrication and overhaul.

On time of the technical deliver, the dealer must to have conducted the user customer about the manutentation, safety, and your obligations in a possible technical assistance, the obligation to see the warranty terms and read the instruction manual. Any solicitation of warranty, please contact our Baldan technical service, by your Baldan dealer that you bought our implement. Reaffirm the necessity to read carefully of warranty certificate and note all of items from this manual, therefore you will increase the working life of your equipment.



Instruction Manual



GTCR

Wheel Type Offset Disc Harrow
Remote Control - Heavy Duty

GTCR-CR

Wheel Type Offset Disc Harrow
Remote Control - Heavy Duty

BALDAN IMPLEMENTOS AGRÍCOLAS S/A.
CNPJ: 52.311.347/0009-06
Insc. Est.: 441.016.953.110



Scan the QR Code on the
identification plate of your
device and access this
Instruction Manual online.

 **BALDAN**

INDEX

01 - SAFETY RULES	4
02 - COMPONENTS	9
03 - TECHNICAL SPECIFICATIONS GTCR / GTCR-CR	11
04 - MOUNTING.....	12
<i>Assemble of front and rear gang.....</i>	<i>14</i>
<i>Mounting of the wheel assembly of a single wheel gtcr/gtcr-cr model with 10 disc blades and the hydraulics that command the system</i>	<i>16</i>
<i>Mounting the wheel assembly of the dual wheel model harrows gtcr 12 - 14 ano 16 disc blades and the hydraulics that command the system</i>	<i>17</i>
<i>Mounting of the wheel assembly of the heavier dual wheel model harrows gtcr / gtcr-cr 18 - 20 - 22 - 24 and gtcr 30 and the hydraulics that command the system.....</i>	<i>18</i>
<i>Assembling of the hitch system.....</i>	<i>19</i>
05 - HITCHING THE HARROW ONTO THE TRACTOR (GTCR / GTCR-CR).....	20
06 - ADJUSTMENTS ANO OPERATION.....	21
<i>Adjustment of the opening of the harrow</i>	<i>21</i>
<i>Displacement of the harrow unit.....</i>	<i>21</i>
<i>Adjustment of the transversal bar.....</i>	<i>22</i>
07 - OPERATION PATIERNs	23
08 – CLEANING	24
09 - LUBRICATION	25
<i>Equivalent gaease table.....</i>	<i>25</i>
10 - LUBRICATION POINTS.....	26
11 - APPROXIMATE HOURLY PRODUCTION	28
12 - IDENTIFICATION	30

01 - SAFETY RULES



THE SAFETY ALERT SYMBOL IDENTIFIES IMPORTANT MESSAGE ON THE MESSAGE ON THE ENGINE, WHEN YOU SEE THIS SYMBOL, BE ALERT TO THE POSSIBILITY OF DEATH OR PERSONAL INJURY. FOLLOW THE INSTRUCTIONS IN THE SAFETY MESSAGE.



WARNING

- Read this instruction manual carefully to know the recommended safety rules.



WARNING

- Only start the tractor operations, when are you properly accommodated and with the seat belt fasted.



WARNING

- Never carry people over the tractor or equipment.



WARNING

- There are risks of serious injury by tipping when working on slopes.
- Never use excessive speed.

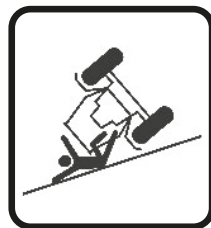

01 - SAFETY RULES



WARNING

- Do not work with the tractor if the front bee without enough weight to the rear equipment. There is tendency to lift , add weights at front or front wheels.



WARNING

- Before any equipment maintenance, make sure that is properly stopped
- Avoid getting hit



WARNING

- Never weld the wheel mounted with tire, the heat may cause air pressure increase and provoke the explosion of the tire.
- When filling the tire, stand at the side of the tire, never in front of it.
- When filling the tire, always use a containment device (filling cage).



WARNING

- Do not perform adjustments while GTCR/GTCR-CR is running.
- When performing any service on GTCR/GTCR-CR, switch off the tractor first. Use appropriate tools.

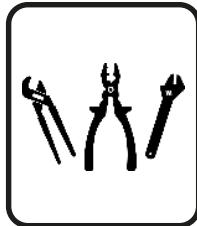

THE SAFETY ALERT SYMBOL IDENTIFIES IMPORTANT MESSAGE ON THE MESSAGE ON THE ENGINE, WHEN YOU SEE THIS SYMBOL, BE ALERT TO THE POSSIBILITY OF DEATH OR PERSONAL INJURY. FOLLOW THE INSTRUCTIONS IN THE SAFETY MESSAGE.

01 - SAFETY RULES

WARNING

- *The hydraulic oil operates pressurized and can cause serious injuries, in case of leakage. Periodically verify the condition of the hoses. If there are any signs of leakage, replace them immediately.*
- *Before connecting or disconnecting hydraulic hoses, release the pressure from the system, activating the control when the tractor is turned off.*



WARNING

- *Keep away from the active seeder elements (discs), they are sharp and can cause accidents.*
- *Whenever performing any work on the discs, wear safety gloves on your hands.*



WARNING

- *Dispose residues inappropriately affects the environment and the ecology since you will be polluting rivers, canals or the soil.*
- *Inform yourself about the proper way of recycling or disposing residues.*

PROTECT THE ENVIRONMENT!



















ALCOHOLIC BEVERAGE OR SOME MEDICATIONS MAY CAUSE LOSS OF REFLEXES AND CHANGE THE OPERATOR'S PHYSICAL CONDITIONS. FOR THIS REASON, NEVER OPERATE THIS EQUIPMENT UNDER ANY OF THESE SUBSTANCES.



WARNING

The incorrect handling of this equipment can result in serious or fatal accidents. Before using the implement, read carefully the instructions of this manual. Be sure that the person responsible for the operation is instructed about the correct handling, safety and if read and understood the instructions manual concerning this machine.

- 01 -  When operate with the implement, do not allow people to stay close or above the implement. (The platforms are used to supply the stores and not to transport people).
- 02 -  During assembly or disassembly the discs section use protection gloves.
- 03 -  When turn on or off the hydraulic rubbers, alleviate the circuit pressure.
- 04 -  Check periodically the rubbers conservation. If there is indicium of oil emptying change it immediatelly because the oil works under high pressure and may cause serious damages.
- 05 -  Do not use much large clothes because they can fasten the implement.
- 06 -  Putting in action the tractor, be correctly placed at the operator seat and aware about the correct and safety handling both tractor and implement. Place always the gearshift crank at the neutral position, turn off the gear of the power command and place the hydraulic commands at the neutral position.
- 07 -  Do not turn on the tractor in a closed place, without appropriate ventilation because the gas are bad for health.

- 08 -  While maneuver the tractor to clamp the implement be sure if there is space enough and nobody is too much close, maneuver always in slow gear and be ready to brake in case of emergency.
- 09 -  Do not adjust the implement working.
- 10 -  Working in inclined soil try to keep the necessary stability. In case of instability reduce the acceleration, turn the wheels to the inclined side of the soil and never lift the implement.
- 11 -  Conduct the tractor always in safety speeds, specially working in irregular or inclined soil, keep the tractor always geared.
- 12 -  In case of conducting the tractor on road, keep the brake pedal connected.
- 13 -  Do not work with the front of the tractor light. If there is trend to lift up add more weight in front or at the front wheels.
- 14 -  Getting out the tractor place the gearshift at the neutral position and apply the park brake. Do never let clamped implements at the tractor with the hydraulic system at the lifted position.
- 15 -  Drugs and alcohol will affect an operator's alertness and coordination. Do not operate any engine under these conditions.
- 16 -  Explain the operation, inspect and maintenance instructions to those users or operators who can not read.

02 - COMPONENTS

FIGURE 1

GTCR - WHEEL TYPE OFFSET DISC HARROW REMOTE CONTROL - HEAVY DUTY

- 01 - Main front frame
- 02 - Main rear frame
- 03 - Main chassis
- 04 - Stabilizer bar
- 05 - Hydraulic piston
- 06 - Hydraulic hoses
- 07 - Wheel axles
- 08 - Wheel articulation
- 09 - Wheels
- 10 - Disc blades
- 11 - Stabilizer rod
- 12 - Stabilizer bar support
- 13 - Transversal bar
- 14 - Hitch beam
- 15 - Hitch shackle
- 16 - Hydraulic hose support

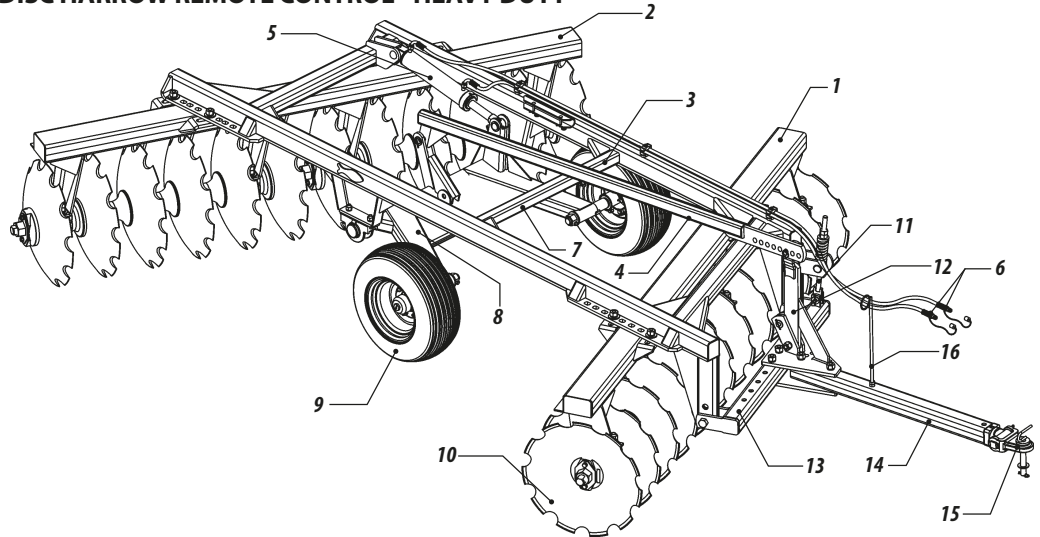

GTCR-CR - WHEEL TYPE OFFSET DISC HARROW REMOTE CONTROL - HEAVY DUTY

FIGURE 2

- 01 - Main front frame
- 02 - Main rear frame
- 03 - Main chassis
- 04 - Stabilizer bar
- 05 - Hydraulic piston
- 06 - Hydraulic hoses
- 07 - Wheel axles
- 08 - Wheel articulation
- 09 - Wheels
- 10 - Disc blades
- 11 - Stabilizer rod
- 12 - Stabilizer bar support
- 13 - Transversal bar
- 14 - Hitch beam
- 15 - Hitch shackle
- 16 - Hydraulic hose support

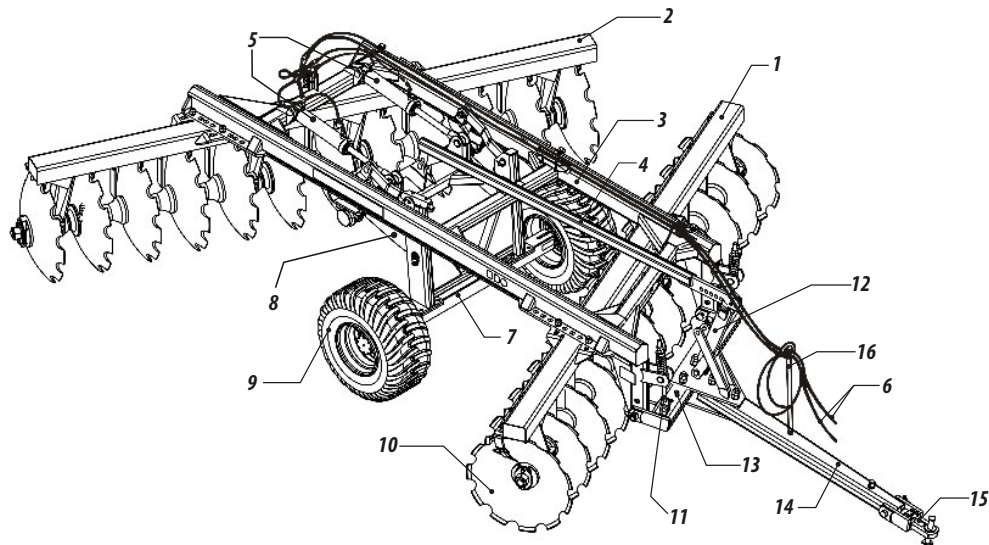

03 - TECHNICAL SPECIFICATIONS GTCR / GTCR-CR

TABLE 1

Model	Nr of discs	Disc spacing (mm)	Disc diameter (ø)	Spherical disc blade (mm)	Axle diameter (ø)	Working width (mm)	Working depth (mm)	Approx. Weight (Kg)		Required tractor power (HP)	Ground wheel
								30"	32"		
GTCR	10	340	30" - 32"	9,0 e 12,0	2.1/4"	1530	200 - 300	1875	1977	90 - 110	Simples
GTCR	12	340	30" - 32"	9,0 e 12,0	2.1/4"	1870	200 - 300	2493	2619	118 - 125	Simples
GTCR	14	340	30" - 32"	9,0 e 12,0	2.1/4"	2390	200 - 300	2632	2821	140 - 150	Duplo
GTCR	16	340	30" - 32"	9,0 e 12,0	2.1/4"	2550	200 - 300	2886	3080	155 - 168	Duplo
GTCR	18	340	30" - 32"	9,0 e 12,0	2.1/4"	2890	200 - 300	3542	3742	175 - 190	Duplo
GTCR	20	340	30" - 32"	9,0 e 12,0	2.1/4"	3230	200 - 300	3833	4053	200 - 210	Duplo
GTCR	22	340	30" - 32"	9,0 e 12,0	2.1/4"	3570	200 - 300	4107	4369	222 - 230	Duplo
GTCR	24	340	30" - 32"	9,0 e 12,0	2.1/4"	3910	200 - 300	4357	4661	240 - 250	Duplo
GTCR	30	340	30" - 32"	9,0 e 12,0	2.1/4"	4930	200 - 300	4798	5112	300 - 320	Duplo

•Optional: Single tyre 7.50 x 16 for models GTCR 10 blades. / Single 7.50 x 16 for models GTCR 12 blades optional double tyre 7.50 x 16. / Double tyre 7.50 x 16 for models GTCR from 14 to 30 blades. / Single tyre 900 x 20 and 400 x 60 for models GTCR from 18 to 30 blades. / Tyre 11L - 15 for models GTCR 16 blades

Model	Nr of discs	Disc spacing (mm)	Disc diameter (ø)	Spherical disc blade (mm)	Axle diameter (ø)	Working width (mm)	Working depth (mm)	Approx. Weight (Kg)	Required tractor power (HP)	Ground wheel
GTCR-CR	18	360	32"	9,0 e 12,0	2.1/4"	3060	200 - 300	3980	175 - 190	400 x 60
GTCR-CR	20	360	32"	9,0 e 12,0	2.1/4"	3420	200 - 300	4180	200 - 210	400 x 60
GTCR-CR	22	360	32"	9,0 e 12,0	2.1/4"	3780	200 - 300	4390	222 - 230	400 x 60
GTCR-CR	24	360	32"	9,0 e 12,0	2.1/4"	4140	200 - 300	4630	240 - 250	400 x 60

Baldan reserves the right to change the technical features of this product without prior warning.
The technical specifications are approximate and informed in the normal working conditions.

TABLE 2

04 - MOUNTING

1 - Before you start... Check if you receive the product without any violation of the packing. In case the cargo has signs of violation, call the insurance agent to witness the fact and assist further unpacking of the cargo for missing items.

2 - Prepare the unloading area for a clean, safe and organized operation and do not allow the people to work without safety material such as gloves.

3 - Assembling normally starts with the disc gangs .The gang components leave the factory pre-mounted without the disc blades.

Carefully dismount the gang , leaving the parts precisely in the same sequence order, without turning the separator spools and bearing housings around, because the extremities of those have a concave face on one and a convex face on the other and this is not so easy to see, if you don't pay attention to it . These faces match with the convex and concave disc surfaces for a tight fit.

4 - Fig (3) shows the mounting sequence of the axle assemblies.

5 - The bearings housings have either a grease nipple or an oil fill plug. Mounted correctly on the harrow, these components should be in the opposite of the drive direction.

FIGURE 3

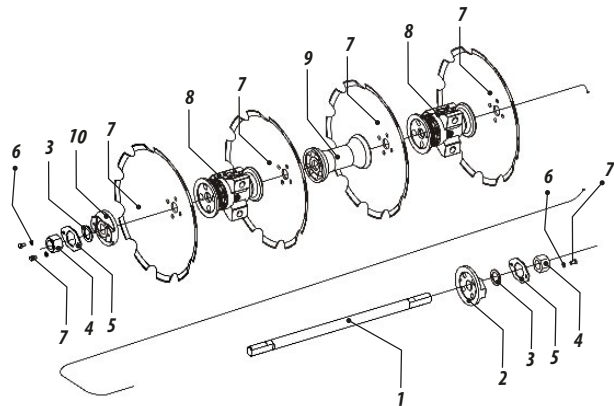

- Figure (4) shows the assembling 01 the disc gang sections for each model of the harrow.

FIGURES 4

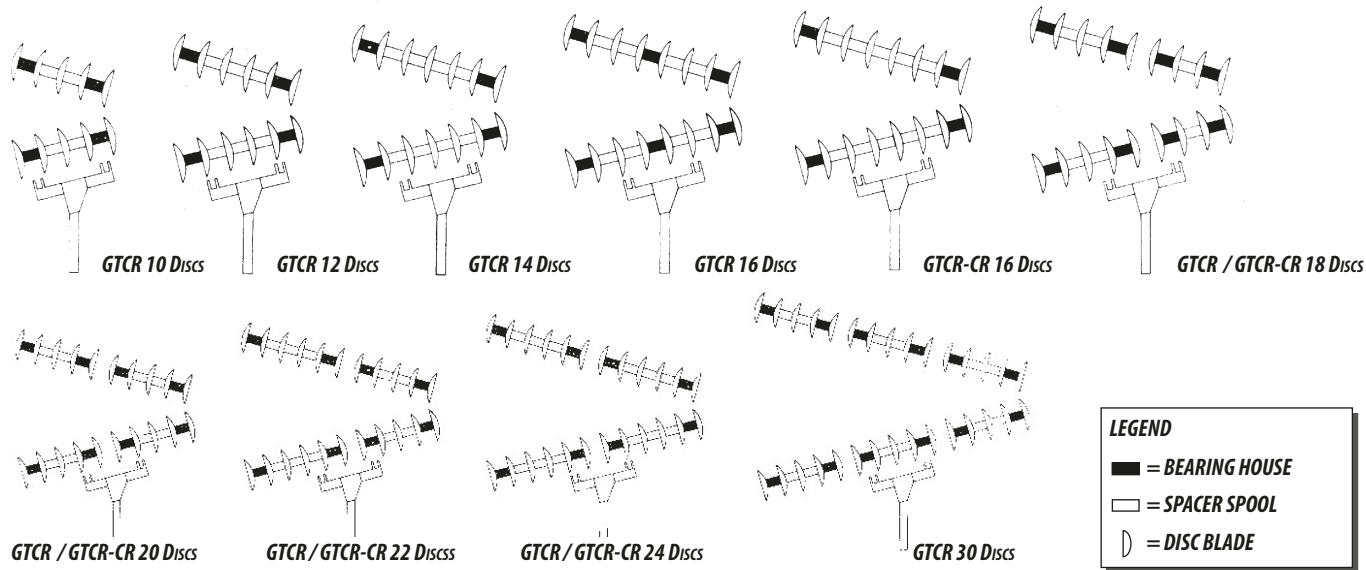

ASSEMBLE OF FRONT AND REAR GANG

Insert the front gang (1 figure 05) and rear (2), in safety terrain.
Install the frame (3) over the gangs and attach using the bolts (4).

FIGURE 5

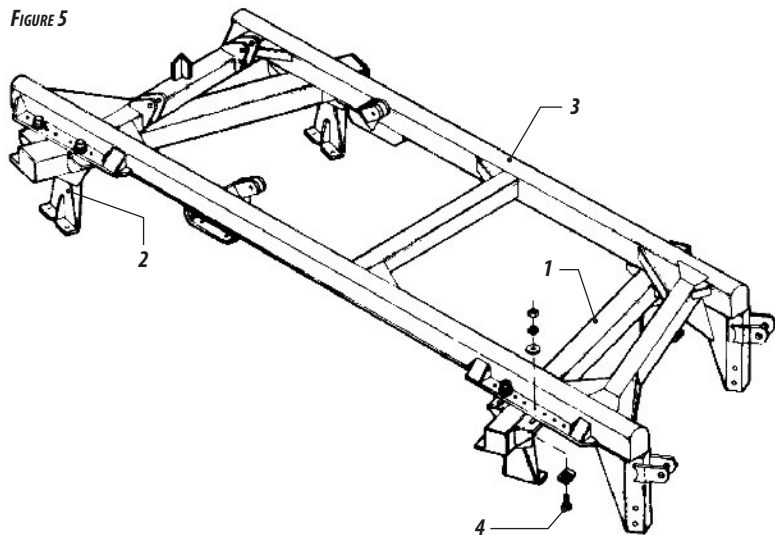

Raise the gang front or rear install the blades as illustrated on the drawing 04, checking the bearing and gang holes are aligned, then mount using the bolt (#1 - Drawing 05), be sure the that the support is turned in a concave direction as illustrated on the drawing 06.

Raise the second gang, install the blades as instructed in the point above between the disc concave face the oposite direction to the first gang.

Also put the wipers central figure 2 item 08, the front and rear frames.

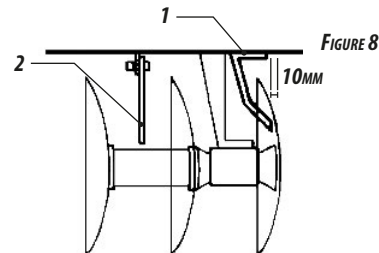
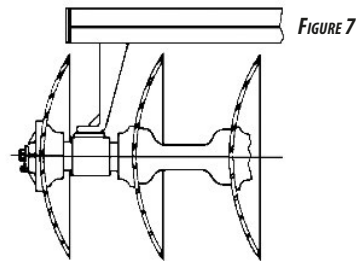
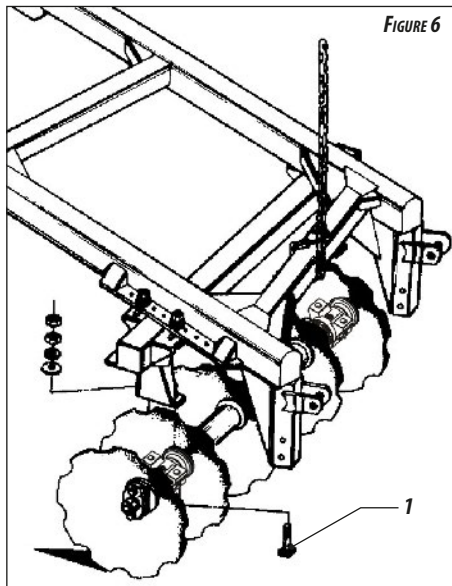

MOUNTING OF THE WHEEL ASSEMBLY OF A SINGLE WHEEL GTCR/GTCR-CR MODEL WITH 10 DISC BLADES AND THE HYDRAULICS THAT COMMAND THE SYSTEM

- Slide the pillow block hubs (2) onto the articulation axles of the wheels (3) and fasten them with the bolts (4), onto the main chassis (1) Now introduce the pre-mounted wheel (5), on the articulation axle (3), place the strut washer, nut (6) and lock the unit, using the appropriate little screw bolt (7).

- Place the hydraulic articulation piston (8) lock the unit using pins (9) and connect the hydraulic hoses (10).

- Connect the stabilizer bar (11) on the articulation system locking the same with pin (12).

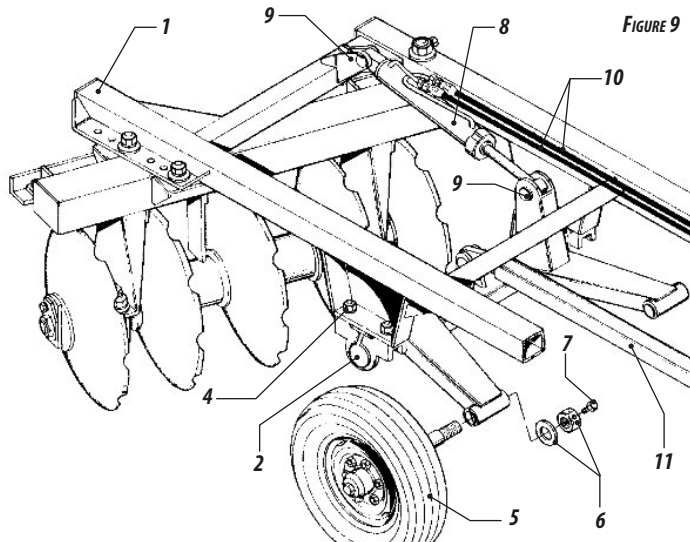

MOUNTING THE WHEEL ASSEMBLY OF THE DUAL WHEEL MODEL HARROWS GTCR 12 - 14 AND 16 DISC BLADES AND THE HYDRAULLCS THAT COMMAND THE SYSTEM

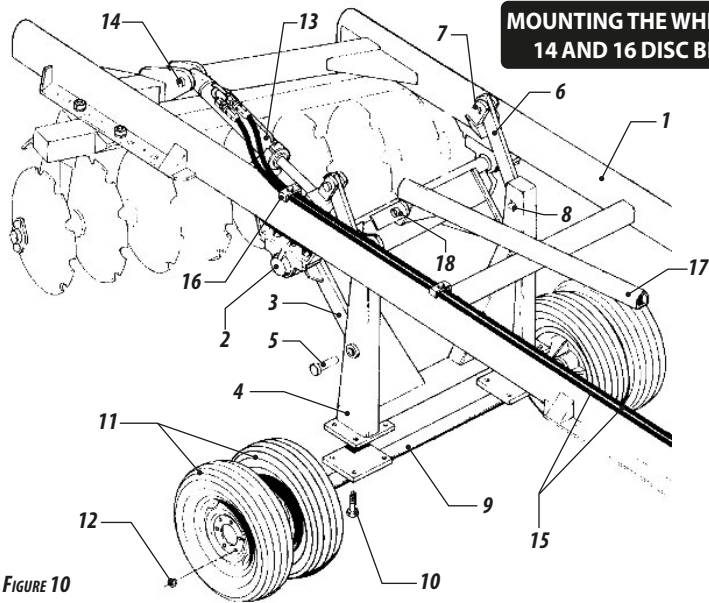

FIGURE 10

Attach the hubs (2) onto the articulationn axle (3) and fasten them onto the main frame (1) with bolts. Place de axle articulation support (4) on the articulation axle (3) and lock il with pins (5). Place the support plate (6) on the coupler of the main frame and lock with pin (7) and on the axle support with pin (8).

- Place the pre-mounted wheel assembly (9) onto the support of the articulation axle and fasten with screw bolts (10).

- Place the hydraulic articulation piston (13) and lock it with pins (14) Connect the hydraulic hoses (15) to the piston and fasten the hoses onto the main chassis (1) with the fasteners (16) as shown in the illustration .

- Connect the stabilizer bar (17) onto the articulations axles and lock it with pin (18).

MOUNTING OF THE WHEEL ASSEMBLY OF THE HEAVIER DUAL WHEEL MODEL HARROWS GTCR / GTCR-CR 18 - 20 - 22 - 24 AND GTCR 30 AND THE HYDRAULICS THAT COMMAND THE SYSTEM.

- Attach the hubs (2) onto the articulation axle (3) and fasten them onto the main frame (1) with the bolts. Place the axle articulation support (4) onto the axle (3) using the pins (5) and lock it with the screw bolt. Fix the plates (6) of the axle support (4) onto the main chassis (1) with pin (7) locking it with screw bolts (10).

- Fasten the wheels (11) onto the axle (9) with bolts (12).

- Place the hydraulic articulation pistons (13) with the base of the cylinder fixed onto the main frame (1) using pin (14) and the other end of the cylinder unit fixed onto the articulation axle with pin (15).

Fasten the hydraulic oil distributor (16) onto the main frame (1). Connect the hydraulic hoses (17) of the piston to the distributor. Connect the hose (18) to the distributor and fix them onto the main chassis with the fasteners (19) supplied, as illustrated. Connect the stabilizer bar (20) onto the articulation axle (3) with pin (21).

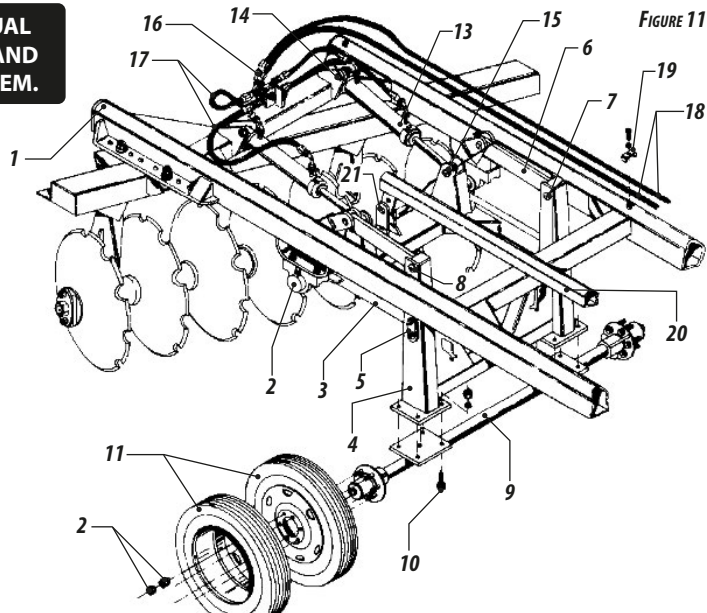

ASSEMBLING OF THE HITCH SYSTEM

- Attach the complete transversal hitch bar (1) onto the main frame (2) with the bolts and nuts (3).
- Introduce the complete stabilizer rod (4) between the plates of the main frame and connect the inferior part of the rod using pin (5).
- Fix the support of the stabilizer bar (6) onto the superior plate on the transversal bar with bolt (7) Connect the front part of the stabilizer bar to the top of the support with pin (9).
- Place the hydraulic hose support (10) onto the toolbar and introduce the hoses through the loop of the same.



NOTE

The illustration shows two stabilizer rods (4) pertaining to the GTCR / GTCR-CR models with 18 - 20 - 22 - 24 and GTCR 30 disc blades. The models GTCR 10 - 12 - 14 and 16 have only one stabilizer rod.

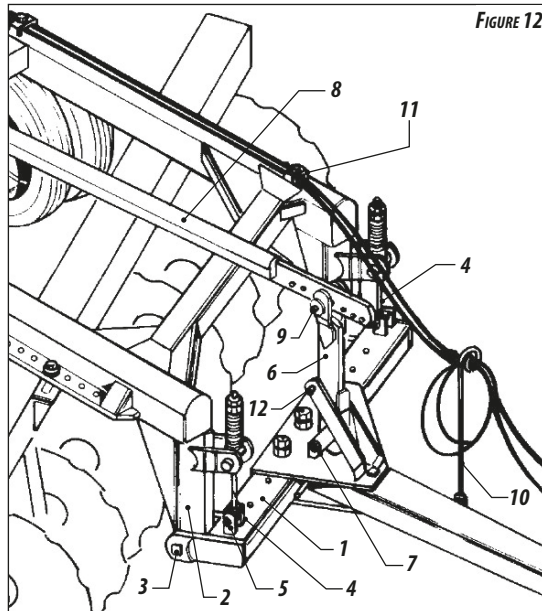

05 - HITCHING THE HARROW ONTO THE TRACTOR (GTCR / GTCR-CR).

- A few reminders when hitching the implement onto the tractor, it is most important to observe the alignment of the harrow. The toolbar once hooked onto the tractor should stay level. Adjust the height as best as possible to obtain this. The harrow should float behind the tractor only then place the hitch pin (1) and make sure it is counter locked.

- For the operation above, find your self a safe and level place with easy access. Always use a reduced gear on the tractor with low acceleration.



ATTENTION

Connect the hydraulic hoses to the quick coupling of the tractor.



NOTE

Before connecting or disconnecting the hydraulic hoses, kill the engine and release the pressure in the hydraulic system of the tractor. Make sure that as ADJUSTMENTS are considered with these operations.

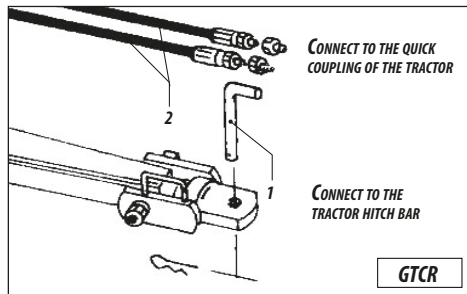

FIGURES 13

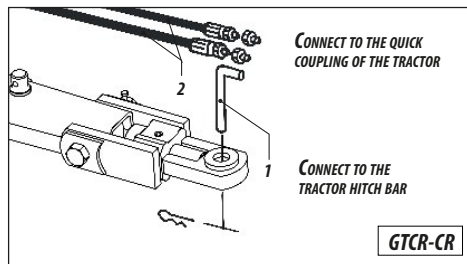

06 - ADJUSTMENTS AND OPERATION

ADJUSTMENT OF THE OPENING OF THE HARROW

- To obtain an ideal disc penetration the attack angle of the disc blades has to be adjusted in accordance with the type and the conditions of the soil:
- In the case of difficult penetration open the harrow angle like shown in figure 14;
- In lighter conditions or loose soils, reduce the opening of the harrow.
- To open or close the harrow, remove the bolts that fasten the trame on the main chassis and move the trame to obtain the ideal adjustment, as indicated by "A" in the illustration.

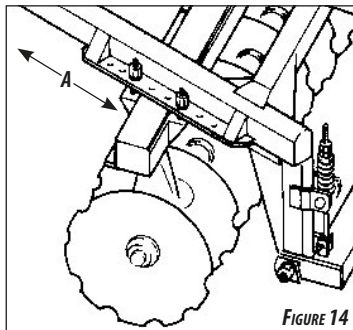

FIGURE 14

- The wheels also assist in adjusting the depth of the disc blades.

DISPLACEMENT OF THE HARROW UNIT

- This displacement comes into consideration when the harrow is not giving a perfect finish that is leaving the wheel trail of the tractor.

The harrow has to work centralized and aligned with the traction of the tractor. To make the required adjustments for this purpose, the superior and inferior plates of the hitch bar can be adjusted to the left or right of the transversal bar as illustrated in Figure 15.

FIGURE 15

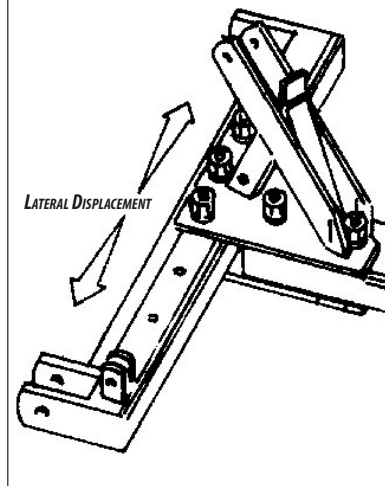

ADJUSTMENT OF THE TRANSVERSAL BAR

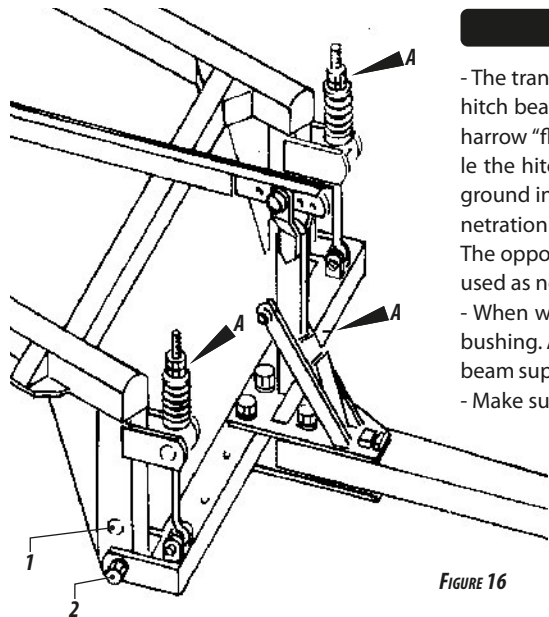

FIGURE 16

- The transversal bar has two fixation points on the main frame (1) and (2). It is important that the hitch beam, that connects implement and tractor, is level when in the operational position so the harrow "floats" evenly over the field. If the transversal bar is hitched to the bottom hole (2) while the hitch beam is sloping up to match the tractor hitch, the harrow will be "lifted out" of the ground in front, reducing penetration, while the pressure transferred to the rear, will increase penetration of the rear part of the harrow.

The opposite will happen when the hitch beam is pulled downwards. These combinations can be used as needed.

- When working, the nut (A) must maintain a minimum distance of 20 mm (1 ") from the spring bushing. Also maintain a minimum distance of the 20 mm between the stabilizer bar and the hitch beam support (A). These spacings are very important to allow the harrow to get the floating effect.

- Make sure the pin (8) of the hitch beam support is pulled out when you are operating.

- This pin is only for the transport position in order to hold the equipment level when the wheels are down for transport, assisted by the adjustment of the overhead stabilizer bar.

07 - OPERATION PATIERNS

- Before entering the field, allow your self another equipment check. Make sure all bolts are tight, disc sections are tight. The tyres are firmly bolted on to the hubs, the bearing housings look alright, the hitch beam pin is pulled. Hoses are not in contact with the ground.

SUGGESTED HARROWING OPERATION

- Where available, always follow the cantours or the terraces of the field. Kaep on lhe right of the terrace leve e (left hand side of the tractor driver).

- Never make a right turn witht the offset.

- The fresh harrowed field should always be on the left of the operator.

HARROW OUTWARDS/INWARDS

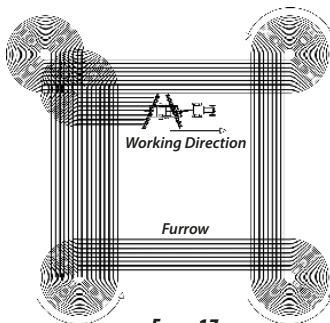
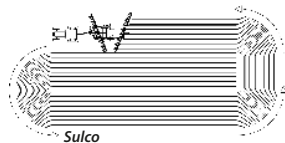

FIGURE 17

HARROW INWARDS/OUTWARDS

This method is more appropriate in sloping land. If you are driving too much on the extremities, start a new plot.



LAND WITH CONTOUR INFRASTRUCTURE

Em terreno com curva de nível é usual começar dois talhões de cada vez, tendo-se o cuidado de iniciar o trabalho com a curva de nível do lado esquerdo do tratorista. Quando chegar no meio da curva de nível, convém começar outro talhão para diminuir o gasto de combustível.

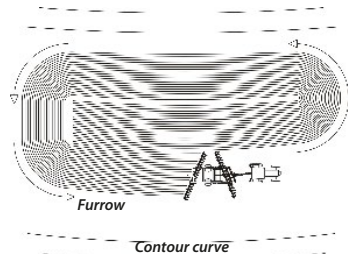

BEARING HOUSING ADJUSTMENTS

- All bearings are heavy duty and built to withstand use.
- However, it is advisable to periodically retighten the bearing flange bolts and rotate the gangs to detect any bearings that might be damaged or worn.
- While we recommend that major overhauls be done whenever possible, emergencies may make it necessary to make some replacements. For this reason, the following material has been compiled to assist you in performing the servicing of the Off Set Disc Harrow.

08 - CLEANING

In the case that the harrow will be inactive for a period of time, provide a general cleaning of the equipment, repaint the harrow and apply a protective oil coat and lubricate the harrow totally. Check the disc blades and if no change is required give them a paint and protective oil coating and store the machine in an appropriate place.

FIGURE 18

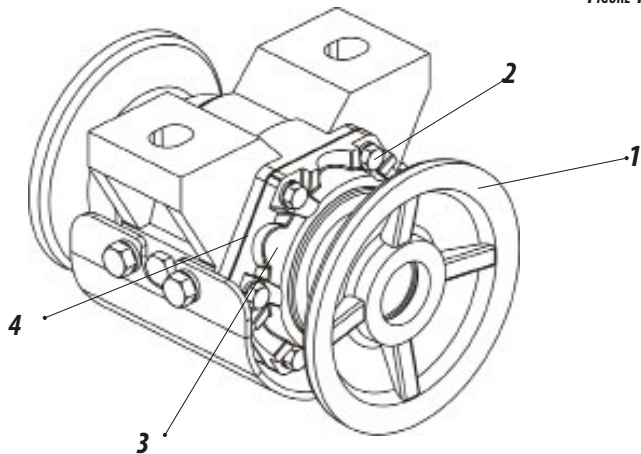

09 - LUBRICATION

- Lubrication is indispensable for an efficient performance and major durability of the moving parts of the implement.
- Before work initiation, carefully lubricate all the grease nipples always considering the grease intervals and the grease quality, avoiding contaminated grease by dirt, earth or water.

LUBRICATION OF GREASE BEARING HOUSINGS

- Clean the grease nipples carefully before applying the grease gun on them. Do not over-grease and clean the excess away.
- Grease bearings should be regreased after every 12 hours of operation with quality grease equivalent to those recommended on the adjacent table.

LUBRICATION OF OIL BEARING HOUSINGS

- During the first working days of the harrow, check the oil levels frequently as well as the retainers.
- Check the oil level every 120 working hours.
- The oil should be changed after every 1200 working hours. Use SAE 90 mineral oil.

EQUIVALENT GREASE TABLE

MANUFACTURER	TYPE OF GREASE RECOMMENDED
Petrobrás	Lubrax GMA 2
Atlantic	Litholine MP 2
Ipiranga	Super Grasa Ipiranga Ipiranga Super Grasa 2 Ipiflex 2
Castrol	LM 2
Mobil	Mobilgrease MP 77
Texaco	Marfak 2 Agrotex 2
Shell	Retinax A Alvania EP 2
Esso	Multipurpose grease H
Bardahl	Maxlub APG 2 EP

TABLE 2



In the case of other lubricants and/or brands of equivalent greases that are not on this table, consult the technical manual of the lubricant manufacturer.

10 - LUBRICATION POINTS

TABLE 3

Item	PART DESCRIPTION	NUMBER OF NIPPLES									OIL CHANGE	LUBRIF. W/ GREASE	TIGHTEN	SUBSTITUTE	CHECK	MAINTENANCE INTERVALS	
		GTCR 10 Discs	GTCR 12 Discs	GTCR 14 Discs	GTCR 16 Discs	GTCR / GTCR-CR 18 Discs	GTCR / GTCR-CR 20 Discs	GTCR / GTCR-CR 22 Discs	GTCR / GTCR-CR 24 Discs	GTCR 30 Discs							
1	Bearing housings	4	4	4	6	8	8	8	8	12		X					12 hours
2	Articulation axls pins	-	2	2	2	2	2	2	2	2		X					
3	Wheel hubs	2	2	2	2	2	2	2	2	2		X					60 hours
4	Axle hubs	2	2	2	2	2	2	2	2	2		X					
5	Hydraulic piston connector	1	1	1	1	2	2	2	2	2		X					
6	Hydraulic piston rod	1	1	1	1	2	2	2	2	2		X					
7	Hitch shackle	1	1	1	1	1	1	1	1	1		X					
8	Articulation support plate	-	4	4	4	4	4	4	4	4		X					
9	Hydraulic system															X	120 hours
10	Oil of the bearing housings															X	
11	Bolts and nuts												X				1200 hours
12	Bearing housings										X						1500 hours
13	Retainers														X		
14	Bearings														X		When necessary
15	Disc blades														X		
16	Tyres														X		

Only **GTCR** has self-lubricating bushings in the “A” clamping hub. These bushings are not used with any kind of grease or lubricant.



ATTENTION

At GTCR, only in the initial assembly of the clamping hub “A”, grease must be inserted in the entire bushing to prevent oxidation on the wheel axle.

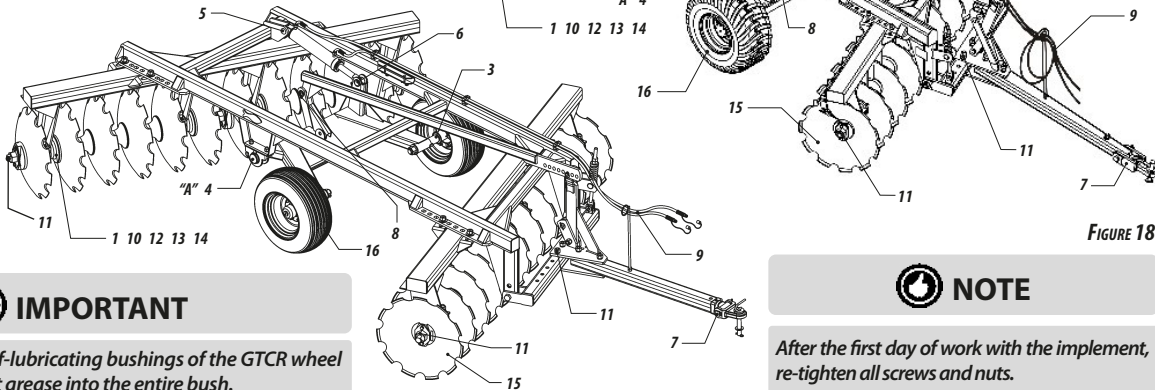

FIGURE 18



IMPORTANT

When replacing the self-lubricating bushings of the GTCR wheel axle “A” hub, also insert grease into the entire bush.



NOTE

After the first day of work with the implement, re-tighten all screws and nuts.

11 - APPROXIMATE HOURLY PRODUCTION

- To calculate the approximate hourly production of GTCR, use the following formula:

- Example: Using a disc harrow with 14 discs, how many Ha it produces in an hour of work at an average speed of 7 km/h?

$$A = ?$$

$$L = 2,39\text{m}$$

$$V = 7.000\text{m/h}$$

$$F = 0,90$$

$$X = 10.000\text{m}^2$$

$$A = \frac{2,39 \times 7.000 \times 0,90}{10.000} = 1,50 \text{ Ha/h}$$

$$A = \frac{L \times V \times F}{X}$$

- To calculate the approximate hourly production of GTCR-CR, use the following formula:

- Example: Using a disc harrow with 20 discs, how many Ha it produces in an hour of work at an average speed of 7 km/h?

$$A = ?$$

$$L = 3,42\text{m}$$

$$V = 7.000\text{m/h}$$

$$F = 0,90$$

$$X = 10.000\text{m}^2$$

$$A = \frac{3,42 \times 7.000 \times 0,90}{10.000} = 2,15 \text{ Ha/h}$$

WHERE:

A = Area to be worked

L = Working width of the disc harrow (in meters)

V = Average Tractor Speed (meters / hour)

F = Production factor - 0.90

X = Hectare value - 10,000 m²

APPROXIMATE HOURLY PRODUCTION TABLE

TABLE 4

MODEL	Working Width (m)	Average Velocity (m/h)	Production Factor	Approximate Production in Hectares
GTCR 10	1,53	7000	0,90	0,96
GTCR 12	1,87	7000	0,90	1,17
GTCR 14	2,39	7000	0,90	1,50
GTCR 16	2,55	7000	0,90	1,60
GTCR 18	2,89	7000	0,90	1,82
GTCR 20	3,23	7000	0,90	2,03
GTCR 22	3,57	7000	0,90	2,25
GTCR 24	3,91	7000	0,90	2,45
GTCR 30	4,93	7000	0,90	3,10
GTCR-CR 18	3,06	7000	0,90	1,93
GTCR-CR 20	3,42	7000	0,90	2,15
GTCR-CR 22	3,78	7000	0,90	2,38
GTCR-CR 24	4,14	7000	0,90	2,60

The formula to calculate the approximate production refers to the calculation of areas to be worked or worked per harrow. To know the time spent working an area of known value, divide the value of this area by the hourly production of the harrow.

Example: What is the time “X” spent on a harrow of 14 discs that produces 35 hectares at an average speed of 7km/hr?

The hourly production of the disc harrow may vary according to factors that alter the work rhythm such as moisture content and soil hardness, slopes, inadequate adjustments and working speed, which are different from the table above, obtained with field work in soils under normal conditions.

$$X = \frac{35 \text{ Ha}}{1,50 \text{ Ha/h}} = 23,3 \text{ horas aprox.}$$

12 - IDENTIFICATION

- To refer to the parts catalog or request Baldan technical assistance, always indicate the model (1), serial number (2) and date of manufacture (3), which is in the harrow identification label.

ALWAYS DEMAND FOR ORIGINAL BALDAN PARTS.

 BALDAN			
BALDAN IMPLEMENTOS AGRÍCOLAS S/A. AV. BALDAN, 1500 NOVA MATÃO CEP 15.993-900 MATÃO-SP BRASIL FONE: (16) 3221-6500 CNPJ: 52.311.347/0009-06 CREA/SP 0170977			
01	Modelo / Model	Data / Date	03
02	Nº de Série / Serial Number	Tipo / Type	
	Capacidade / Load Capacity	Peso / Weight	



PUBLICATIONS

Code: 6055010391-8
CPT: GTCR103004520A



WARNING

The drawings in this instructions manual are for illustrative purposes only. To enable a better overview and detailed instructions, on some drawings in this manual, safety devices (covers, shields, etc..) were removed. Never operate the agricultural wagon without these devices.



CONTACT

*If you have questions, never operate the GTCR/ GTCR-CR see the post sale.
Phone: 0800-152577
e-mail: posvenda@baldan.com.br*

CERTIFICATE OF WARRANTY

- 01 - **BALDAN IMPLEMENTOS AGRÍCOLAS S/A**, guarantee the normal operation of the product for a 6 (six) months period dated from the dealer's bill of sale to the first final customer.
- 02 - During this period, **Baldan** compromise itself to repair the material or manufacturing defects, but the labour, the freight and other expenses are the dealer's responsibility.
- 03 - At the guarantee period, all the request and replacement of any defective part must be made to the dealer of the region, which will send the defective part for analysis at **Baldan**.
- 04 - When this procedure won't be possible and the dealer couldn't have the ability to solve the problem, the dealer can ask for **Baldan's Technical Assistance** using the specific form delivered to them.
- 05 - After the analysis of the items replaced by **Baldan Technical Assistance** and if we conclude that it wasn't a guarantee problem, then the dealer will be the responsible for all costs related to the replacement; as well as material expenses, travel including accommodation and meals, also the accessories, lubricant used or any other expenses after having called the Technical Assistance. And, withal, the company Baldan is authorized to issue the billing in name of the respective reseller.
- 06 - Any repair made to the product which is in warranty period by the dealer, will only be authorized by Baldan after budget previous presentation describing pieces and labour to be accomplished.
- 07 - It is out of this term the product which has repairs or modifications not made by dealers from Baldan's network, as well as pieces applications or not authentic components to the product by the user.
- 08 - This certificate of guarantee will become invalid when notice that the damage or defect is the result of incorrect use of the product, of instructions non-observance or operator's inexperience.

- 09 - It's stipulated that this guarantee don't cover tires, polyethylene deposits, universal joints, hydraulic components, etc, wich equipments are guarantee by their manufacturers.
- 10 - The material or manufacture defects, object of this certificate of guarantee, will not be, by any hypotesis, reason for cancellation of the contract of sale, or indemnity of any kind.
- 11 - For a warranty solicitation to the distributor, you have to proceed in the following manner:
- 12 - Send the technical informe detailed telling the problem (technical assistance request form to the client), you can find it send us an email to **after-sales@baldan.com.br** or acessing our website.
- 13 - If it's possible send films and photos from the requested spare parts.
- 14 - To point at the form: serial number, manufacture year, etc, that is, all information asked at the form. The damage spare parts should be available for analysis of the the after sales department in a future visit (in case of requested).
- 15 - **Baldan** keeps the right of changing and or improve the technical characteristics of its products, without notice and without the obligation of act like this way with its previously manufactured products.

INSPECTION AND DELIVERY CERTIFICATE

- **SERVICE BEFORE THE DELIVERY:** This equipment was very carefully prepared by the dealer's organization, inspected in all its parts in agreement with the manufacture's prescription.
- **DELIVERY SERVICE:** The user was informed about the current guarantee terms and instructed about maintenance care and utilization.
- I confirm that I was informed about the current guarantee terms and instructed about the correct utilization and maintenance of this product.

Product: _____ *Serial number:* _____

Date: _____ *Bill of sale:* _____ *Store:* _____

City: _____ *State:* _____ *Zip code:* _____

Owner: _____ *Phone:* _____

Adress: _____ *Number:* _____

City: _____ *State:* _____

E-mail: _____ *Date of sale:* _____

INSPECTION AND DELIVERY CERTIFICATE

- **SERVICE BEFORE THE DELIVERY:** This equipment was very carefully prepared by the dealer's organization, inspected in all its parts in agreement with the manufacture's prescription.
- **DELIVERY SERVICE:** The user was informed about the current guarantee terms and instructed about maintenance care and utilization.
- I confirm that I was informed about the current guarantee terms and instructed about the correct utilization and maintenance of this product.

Product: _____ *Serial number:* _____

Date: _____ *Bill of sale:* _____ *Store:* _____

City: _____ *State:* _____ *Zip code:* _____

Owner: _____ *Phone:* _____

Adress: _____ *Number:* _____

City: _____ *State:* _____

E-mail: _____ *Date of sale:* _____

INSPECTION AND DELIVERY CERTIFICATE

- **SERVICE BEFORE THE DELIVERY:** This equipment was very carefully prepared by the dealer's organization, inspected in all its parts in agreement with the manufacture's prescription.
- **DELIVERY SERVICE:** The user was informed about the current guarantee terms and instructed about maintenance care and utilization.
- I confirm that I was informed about the current guarantee terms and instructed about the correct utilization and maintenance of this product.

Product: _____ Serial number: _____

Date: _____ Bill of sale: _____ Store: _____

City: _____ State: _____ Zip code: _____

Owner: _____ Phone: _____

Address: _____ Number: _____

City: _____ State: _____

E-mail: _____ Date of sale: _____

3ª Page - Manufacturer

Please send this filled copy to Baldan, until 15 days after the purchase.

Signature / Store's stamp _____



Avenida Baldan, 1500
Nova Matão
15.993-900
Matão/SP - Brasil
sac@baldan.com.br
export@baldan.com.br

+55 16 3221 6500
baldan.com.br