

Serafin MACHINERY

YOUR SEEDING & TILLAGE SPECIALISTS

NARROW FOLD SINGLE DISC



OPERATOR MANUAL

Serafin ULTISOW

Table of Contents

Introduction	3
IMPORTANT NUMBERS	3
Conservation Agriculture	4
No-Till Systems	4
General Information	5
Safety	6
Operation of the Machine	6
Disconnecting the Machine	6
Operator Safety	7
Personal Protective Equipment – PPE	8
Crushing Hazards	9
Connecting or Disconnecting Implement Hazards	10
High Pressure Hydraulic Fluid Hazards	11
Environmental Hazards	12
Hazards when maintaining the Machine	13
Before You Start	15
Checklist	15
Tighten Wheel Nuts & Bearings	15
Guidelines for Use	15
Connecting to the Seed Box	16
Checking the Wing Fold Operation	16
Seed Unit Hydraulic Down Pressure System	16
Transport Guidelines	17
Transport on Public Roads	17
Manual/Electric Pressure Valve Setup	18
Machine Operation/Field Setup	19
Lubrication	20
Seeding Unit	20
Grease Points	21
Maintenance	23
Maintaining the Machine	23
Replacing Discs/Seed Boot Adjustment	23
Disc Wear	24
Effects of Worn Discs	24
Wheel Studs / Rims	25
Cleaning & Storage	26
Tyres	26
Gason Quick Reference Guide	27
Troubleshooting	31
PARTS CATALOGUE	33

INTRODUCTION

Congratulations on the purchase of your new SERAFIN ULTISOW!

Serafin Machinery is based in Griffith, NSW in the heart of one of Australia's leading agricultural centres. Serafin Machinery has more than 20 years' experience in manufacturing and designing high quality farm machinery for some of the most demanding farming requirements.

The team at Serafin Machinery are totally committed to the No-Till concept of disc seeders for cereals and pastures. Serafin Machinery's dedicated parts support and back up service ensures customers receive exceptional service every time.

Our aim is to continually improve our machinery to ensure low maintenance costs, reliability and long-lasting machinery that does the best job possible.

Serafin Machinery work hard to keep developing new models of seeders to meet the demand of our future customers and strive for continual improvement of our imported components from our suppliers. We hope you enjoy using your new seeder as much as we enjoyed producing it.

Happy planting!

IMPORTANT NUMBERS

Serafin Machinery – Head Office	02 6963 5588
Spare Parts Manager	0458 635 588
Service Manager	0487 055 588
Sales Manager	0459 755 881

Check us out online – serafinmachinery.com.au

CONSERVATION AGRICULTURE

According to the FAO (Food and Agriculture Organization of the United Nations), “Conservation Agriculture” (CA) aims to achieve sustainable and profitable agriculture and subsequently aims at improved livelihoods of farmers through the application of the three CA principles: Minimal soil disturbance, permanent soil cover and crop rotations.

CA holds tremendous potential for all sizes of farms and agro-ecological systems, but its adoption is perhaps most urgently required by smallholder farmers, especially those facing acute labour shortages. It is a way to combine profitable agricultural production with environmental concerns and sustainability and it has been proven to work in a variety of agro-ecological zones and farming systems. It is been perceived by practitioners as a valid tool for Sustainable Land Management (SLM).”

Head to the Food and Agriculture Organisation website for more information:
<http://www.fao.org/ag/ca/index.html>

NO-TILL SYSTEMS

“No-Tillage” is a ‘cornerstone’ of CA and can be practiced in both large and small farming systems. With No-Till (also termed zero tillage and direct drilling) the only tillage operations are low disturbance seeding techniques for the application of seeds and fertilisers directly into the stubble of the previous crop. Gradually, organic matter of the surface layers of zero tilled land increases, due to reduced erosion, increasing yields and resulting in more crop residue added to the soil surface.

Gradually, organic mulch is developed on the soil surface, and this is eventually converted to stable soil organic matter because of reduced biological oxidation compared to conventionally tilled soils. No-Tillage is effective in mitigating many of the negative on-farm and off-site effects of tillage, principally humidity loss, organic matter loss, reduced biodiversity and reduced runoff. These conditions are replaced with permanent soil cover, improvements in soil structure, improved organic matter status, improved water use efficiency and improved soil biology and nutrient cycling.



GENERAL INFORMATION

Read this manual carefully to learn how to operate and service your machine correctly. Failure to do so could result in personal injury or equipment damage and will not be covered by the warranty and/or insurance.

This manual is part of your machine and must always remain with the machine. Right hand and left-hand sides are determined by facing in the direction the machine will travel when going forward.

Warranty is provided as part of the Serafin Machinery support program for customers who operate and maintain their equipment as described in this manual. The warranty is explained on the warranty certificate which you will receive when the machine is delivered.

Set up is the responsibility of the operator. Correct seed depth and amount of soil coverage is adjustable for each sowing situation. Cover and press wheel pressure are also adjustable. There is no standard factory setting for all situations as each requirement is different.

Serafin Machinery will demonstrate all adjustments necessary on set up of machine.

Serafin Machinery will NOT be responsible or liable for seeding rate, depth of seed/fertiliser or closing wheel pressures.

Consult your agronomist for sowing depth and seeding rate.

SAFETY

Read all safety instructions before operating the machine. If you do not understand any part of this manual and need assistance, please contact Serafin Machinery.



Operation of the Machine

- Carefully read and understand the instruction manual before use.
- Serafin Machinery will instruct correct use of the machine during installation/delivery. It is the owner's responsibility to train staff/operator prior to using the machine.
- Ensure no one is near the machine while it is attached to the tractor and the tractor is running.
- Incorrect handling of this equipment could result in serious or fatal accidents.
- Adhere to all working (12km/h) and transport (30km/h) speeds, in rough terrain and turning speeds will need to be reduced further to prevent damage or roll over.
- Unauthorised modifications to the machine may impair the function and/or safety and effect machine life. This will also void warranty.

Disconnecting the Machine

- Be sure to clear the area around the machine before raising or lowering the machine or wings.
- Stop the tractor on level ground before raising or lowering wings.
- Operate the machine from the tractor seat only.
- Ensure safety locks are fitted to wings if storing in folded position.
- Lower machine to the ground
- Turn tractor off and remove key.
- Release any hydraulic pressure on remotes.
- Disconnect hydraulic couplers, electric couplers and any primary hose breakaway couplers and fold onto machine.
- Disconnect hitch from tractor.

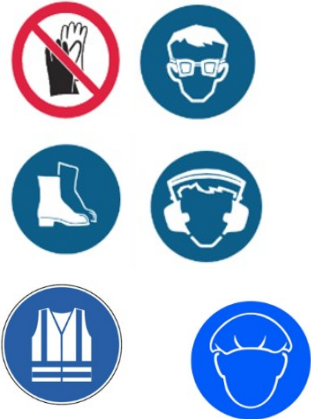
OPERATOR SAFETY

			
<p>Read and understand Operators manual</p>	<p>Wear appropriate Personal Protective Equipment</p>	<p>Do not operate machine when under the influence of drugs or alcohol</p>	<p>Use Seat Belts</p>



WARNING

TO AVOID SERIOUS INJURY OR DEATH DO THE FOLLOWING:

- **READ, UNDERSTAND** and **FOLLOW** Operator's Manual instructions, Warnings and Safety Messages.
- **WEAR PERSONAL PROTECTIVE EQUIPMENT** when operating or repairing equipment.
- **DO NOT USE DRUGS** or **ALCOHOL** before or while operating equipment
- **DO NOT ALLOW** anyone to operate equipment under the influence of drug or alcohol.
- **CONSULT** medical professional for medication impairment side effects.
- **STAY ALERT**, prolonged operation can cause fatigue; **STOP** and **REST**.

GENERAL OPERATING SAFETY

Visibility Conditions while in use

- OPERATE IN DAYLIGHT or with lights that give clear workplace visibility
- Tractor operator must be able to see seeder operation without obstruction
- Tractor operator must be able to see ahead and avoid obstructions while operating equipment

Ground Speed while operating

- Operator should control ground speed to achieve optimum seeding performance
- Adjust working speed to suit terrain conditions
- Reduce speed near steep slopes, ditches or foreign objects

Safety Signs and Warning Decals

- Replace missing, damaged or unreadable safety signs immediately

Safety Shielding and Sensors

- Never remove or modify any safety devices

Communication

- Verbal communication can be difficult and dangerous near the seeder
- Operating instructions and directions should be made prior to operation
- Never allow anyone to approach seeder while in operation

Riding Passengers

Never allow passengers to ride on seeder.

PERSONAL PROTECTIVE EQUIPMENT - PPE

			
Wear hearing protection	Wear Hi-Visibility clothing.	Wear eye protection.	Wear enclosed footwear.

WE RECOMMEND THIS MACHINERY IS USED WITH A TRACTOR THAT IS FITTED WITH A CABIN. IF THE OPERATION OF THIS EQUIPMENT IS DONE USING A TRACTOR WITH AN OPEN CABIN, IT IS SUGGESTED THAT PERSONAL PROTECTIVE EQUIPMENT IS WORN BY THE OPERATOR.

ALWAYS FOLLOW SUGGESTIONS CONCERNING ALL PROTECTIVE CLOTHING AND PERSONAL PROTECTIVE EQUIPMENT ISSUED TO YOU, OR CALLED BY FOR THE JOB CONDITIONS. THIS SHOULD ALWAYS INCLUDE;

- **USE HEARING PROTECTION** if using open cab tractor to stop hearing fatigue when operation for extended times
- **WEAR HI VISIBILITY CLOTHING** to ensure you are visible to others on the worksite
- **WEAR EYE PROTECTION** if using open cab tractor to stop dust or other foreign matter entering your eyes
- **WEAR SAFETY FOOT WEAR** to protect feet from crush hazards
- **RESPIRATION PROTECTION** if using open cab tractor to stop dust or other foreign matter entering your lungs

CRUSHING HAZARDS



STAY CLEAR OF MACHINE WHILE HYDRAULIC SYSTEM PRESSURISED



DEPRESSURISE HYDRAULIC SYSTEM TO AVOID SERIOUS INJURY OR DEATH FROM ACCIDENTAL MACHINE MOVEMENT CAUSING POTENTIAL CRUSH INJURIES.

THIS SEEDER USES HYDRAULIC ACTUATION TO MOVE PARTS DURING OPERATION OR WHILE STATIONARY. BE AWARE OF CRUSHING HAZARDS WHEN THE MACHINES HYDRAULIC SYSTEM IS PRESSURISED.

TO AVOID CRUSH INJURIES

- **OPERATE FROM TRACTOR SEAT** never operate machine from the ground or in close proximity to moving parts.
- **DO NOT OPERATE WHILE MAINTAINING MACHINE** ensure all people are clear prior to operation.

TO AVOID FALLING OFF IMPLEMENT

- **USE EXTREME CARE WHEN CLIMBING ONTO EQUIPMENT.** Always use three-point contact using available handles and steps on implement while exiting.
- Never attempt to mount the implement while unit is moving.



TO AVOID CHILDREN FALLING OFF OR BEING CRUSHED BY EQUIPMENT:

- **NEVER ALLOW** children to play on or around tractor or equipment.

CRUSHING BY TRAPPING FINGERS/HANDS/ARMS in EQUIPMENT

- **KEEP ARMS AND LEGS CLEAR** of hydraulic actuators and ground engaging parts
- **KEEP SEATED** while operating the machinery
- **LOWER WINGS AND ROW UNITS AND STOP TRACTOR ENGINE** before attempting maintenance
- **KEEP CLEAR OF TRACTOR DRAWBAR** when connecting and disconnecting machine

CONNECTING OR DISCONNECTING IMPLEMENT HAZARDS

		
<p>FOOT CRUSHING HAZARD</p>	<p>HAND CRUSH</p>	<p>STOP TRACTOR, REMOVE KEY READ OPERATING MANUAL</p>

 **WARNING** TO AVOID SERIOUS INJURY OR DEATH FROM BEING CRUSHED BY TRACTOR OR IMPLEMENT:

WHEN ATTACHING UNIT TO TRACTOR:

- **DO NOT ALLOW BYSTANDERS** between tractor and seeder
- **KEEP HANDS AND BODY CLEAR** of drawbar and fold points

BEFORE CONNECTING OR DISCONNECTING COMPONENTS

- **STOP TRACTOR ENGINE** before connecting hydraulic hoses.

WHEN CONNECTING OR DISCONNECTING SEEDER TO TRACTOR DRAWBAR OR LINKAGE:

- **DO NOT CRAWL OR WALK** under seeder whilst in storage position

HIGH PRESSURE HYDRAULIC FLUID HAZARDS



HYDRAULIC FLUID INJECTION
HAZARD



WARNING

TO AVOID SERIOUS INJURY OR DEATH FROM HYDRAULIC FLUID INJECTION INJURY:



WHEN ATTACHING HYDRAULIC HOSES:

- **INSPECT HOSES** for wear and leaks prior to connecting implement to tractor
- **INSPECT HYDRAULIC COUPLINGS** for leaks and damage whilst connecting to tractor

WHEN USING THE IMPLEMENT

- **CHECK ALL HOSES FOR WEAR & LEAKS** prior to operating implement.

ENVIRONMENTAL HAZARDS

		
<p>DUST HAZARD</p>	<p>NOISE HAZARD</p>	<p>DUST HAZARD</p>



IMPORTANT TO AVOID INJURY FROM DUST INJECTION OR TEMPORARY HEARING ISSUES IS RECOMMENDED:

We recommend operation of this seeder be done using a tractor with a cabin. If you intend to use this implement with an open type tractor cabin, observe the following use of Personal Protective Equipment;

WHEN IMPLEMENT IS IN OPERATION:

- **USE RESPIRATION PROTECTION** to reduce dust ingestion
- **WEAR HEARING PROTECTION**
- **WEAR GOGGLES** to reduce dust irritating the operators eyes

HAZARDS WHEN MAINTAINING THE MACHINE

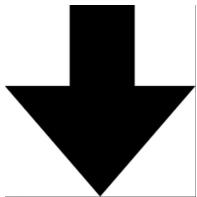
		
<p>PERIODICALLY INSPECT ALL MOVING PARTS AND TIGHTEN ALL FASTENERS</p>	<p>STOP TRACTOR ENGINE & HYDRAULICS BEFORE CONDUCTING MAINTENANCE</p>	<p>PLACE UNIT ONTO GROUND BEFORE DOING ANY MAINTENANCE</p>



AVOID SERIOUS INJURY OR DEATH FROM COMPONENT FAILURE BY KEEPING IMPLEMENT IN GOOD OPERATING CONDITION BY PERFORMING CORRECT SERVICE, REPAIRS, AND MAINTENANCE.



BEFORE CARRYING OUT ANY MAINTENANCE ENSURE THE TRACTOR ENGINE IS SWITCHED OFF, KEY REMOVED AND PARK BRAKE ENGAGED.

BEFORE PERFORMING SERVICE, REPAIRS, AND MAINTENANCE ON THE IMPLEMENT:



SECURE EQUIPMENT FOR SERVICE

- **STOP TRACTOR ENGINE** , engage parking brake, and allow all moving parts to stop
- **LOWER WINGS ONTO GROUND** Before commencing work
- **CYCLE HYDRAULIC CONTROLS** to release any trapped hydraulic pressure

WEAR SAFETY GLASSES, PROTECTIVE GLOVES AND FOLLOW SAFETY PROCEDURES WHEN PERFORMING SERVICE, REPAIRS, AND MAINTENANCE ON THE IMPLEMENT:

- Always **WEAR GLOVES** to guard against worn component with sharp edges.
- Always **WEAR SAFETY GLASSES** when servicing components
- **AVOID CONTACT** with hot hydraulic oil.
- **SECURELY** support or **BLOCK UP** raised implement, framework, and lifted components before working underneath equipment.
- **STOP** any implement movements and **SHUT-OFF TRACTOR** engine before doing any work procedures.
- **USE** stepladder or raised stands to reach high equipment areas inaccessible from ground.
- **ENSURE** good footing by standing on solid flat surfaces when getting on implement to perform work
- **FOLLOW** manufacturer's instructions in handling oils, solvents, cleansers, and other chemical agents.
- **DO NOT** change any factory-set hydraulic calibrations to avoid component or equipment failures.
- **DO NOT** modify or alter implement, functions or components.

HAZARDS WHEN MAINTAINING THE MACHINE (CONTINUED)

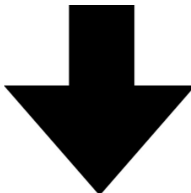
		
<p>PERIODICALLY INSPECT ALL MOVING PARTS AND TIGHTEN ALL FASTENERS</p>	<p>STOP TRACTOR ENGINE & HYDRAULICS BEFORE CONDUCTING MAINTENANCE</p>	<p>PLACE UNIT ONTO GROUND BEFORE DOING ANY MAINTENANCE</p>



AVOID SERIOUS INJURY OR DEATH FROM COMPONENT FAILURE BY KEEPING IMPLEMENT IN GOOD OPERATING CONDITION BY PERFORMING CORRECT SERVICE, REPAIRS, AND MAINTENANCE.

PERFORM SERVICE, REPAIRS, LUBRICATION AND MAINTENANCE OUTLINED IN IMPLEMENT MAINTENANCE SECTION:

- **INSPECT** before each use for loose fasteners, worn or broken parts, leaky or loose fittings and all moving parts for wear.
- **REPLACE** any worn or broken parts with new parts.
- **LUBRICATE** unit as specified by maintenance checklist.
- **NEVER** lubricate, adjust or remove material while it is running or in motion.
- **TORQUE** all bolts and nuts as specified.
- **CHECK** tire conditions.
- **AVOID CONTACT** with recently used equipment that may still be hot.
- **DO NOT MODIFY** or alter equipment
- **DO NOT CRAWL** or walk under unsecured raised equipment.

SAFETY SHIELDS, GUARDS AND SAFETY DEVICES INSPECTION:

- **MAINTAIN SAFETY SIGNS** and Decals in good readable condition.
- **REPLACE** any missing, broken or worn safety shields, guards and safety devices.

BEFORE YOU START

Check List

1. Read and understand operator's manual on how to operate correctly.
2. Check tyre pressure and inflate to required pressure minimum (40 PSI). Refer to page 26
3. Lubricate frame and units with recommended grease at stated service intervals. Refer to Page 20
4. Inspect for loose, damaged or missing parts. Repair or replace before use.
5. Make sure air and hydraulic hoses do not interfere with moving parts. If there is interference, relocate hoses and secure in position.

Tighten Wheel Nuts & Wheel Bearings

Tighten all wheel nuts after first 4 hours and wheel bearings during the first week of operation and check periodically after that. Refer to page 25. This is a part of general servicing.

To adjust wheel bearings:

1. Jack up machine.
2. Remove centre hub cap and split pin.
3. Tighten nut until there is a slight drag on the bearings, while turning wheel.
4. Back nut off until split pin can be placed in hole.
5. Replace hub cap.
6. Torque wheel nuts to 255ftlb as per recommendation page. Refer to page 25.

Guidelines for Use

1. Ensure units are fully raised before lowering or raising the wings.
2. Clear wing area of people and obstacles and ensure locking pins are removed before lowering or raising the wings.
3. Raise units fully out of the ground before making sharp turns, such as at row ends or turnarounds or when backing up the machine.
4. Have machine moving forward before lowering units, to avoid blockages.
5. When units are in working position, operate at a maximum ground speed of up to 12 km/h. If conditions are rough or unfavourable you will need to reduce your ground speed to suit.
6. Travelling speed with units raised and wings folded is a maximum of 30km/h. It is desirable to run machine in straight lines and refrain from 90 degree turns. As this will create excess wear of the seeding unit and possible damage to the cover wheel arm.

Connecting to the Seed Box

- Ensure all hydraulic lines and machine connections are in correct position before operation.
- Check that couplers are clicked in correctly, especially on low pressure return or case drain hoses to avoid blowing motor seals on fan.

Checking the Wing Fold Operation

1. Ensure units are fully raised and locking pins removed before lowering or raising the wings.
2. Keep all persons away from the machine when raising or lowering wings.
3. Always locate machine on level ground when raising or lowering wings.
4. Never raise or lower wings when moving.
5. Use with care when raising wings near electricity lines to avoid contact. Serious injury or death can result from contact with electricity lines.

Seed Unit Hydraulic Down Pressure System

NOTE: The active hydraulic system requires a tractor with closed-centre or pressure/flow compensated hydraulics. Valve set up is on page 18.

The active hydraulic system keeps the depth wheels in contact with the soil surface to follow ground contours over uneven terrain. The setting of the depth wheels determines seed depth, NOT the hydraulic pressure.

The amount of hydraulic pressure needed to keep the depth wheels in contact with the surface depends upon soil compaction, moisture and stubble covering. Too little pressure causes insufficient spring compression and inconsistent disc penetration resulting in uneven seed depth. Excess pressure can cause premature damage to the depth wheel tyre, rim and shaft.

TRANSPORT GUIDELINES

1. Proceed cautiously under overhead power lines and around utility poles.
2. Know the transport height and width of your machine.
3. Electrocutation can occur with direct contact to overhead electrical lines.
4. Always fold wings fully and install transport locks before transport.
5. Do not transport with tractor that under specified for this seeder - EG: Too light.
6. When transporting, latch the tractor brakes together.
7. To improve stability when travelling through the field, wings should be unfolded from transport position as soon as possible after leaving the roadway.
8. Adhere to recommended MAX speed 30km/h.

Transport on Public Roads

1. Always travel at a reasonable and safe speed. Never exceed 30 km/h.
2. Always use the flashing warning lights when transporting on public roadway. Keep reflective material and flags clean and visible. Ensure oversize signs are fitted and visible – front and rear.
3. Prevent collisions between motorist and slow-moving equipment on public roads.
4. Frequently check for traffic from the rear, especially in turns and use the turn signals.
5. Shift the tractor into a lower gear when transporting down steep slopes or hills.
6. It is not recommended to transport with seed or fertiliser in bins.
7. Never transport the machine with air seeder fan running.
8. It is recommended you check the Roads and Maritime Services website for rules and regulations while transporting agricultural machinery in your area.

Head to the RMS website for more information: <https://www.rms.nsw.gov.au/>

MANUAL/ELECTRIC PRESSURE VALVE SET UP

Down pressure is important to ensure even seed depth across the machine on variable soil conditions. But the depth wheel is the main control for depth. Each paddock can vary in soil hardness, so adjust accordingly.

- There is a Hex head screw under the manual valve. See image below.
- Loosen the lock nut, to reduce pressure turn the screw anti clockwise, to increase pressure turn clockwise.
- To set pressure lower the units, drive forward five metres then check the depth wheels. Optimum pressure you should be able to just turn the depth wheel while the disc is in the ground. This way most of the pressure is on the disc not the depth gauge wheel. The depth wheel is designed to follow the ground, not carry the unit or the machine.
- Excess pressure will cause damage to the depth wheel rims and tyres and may void your warranty.
- Pressure ranges between 500psi and 800psi are considered to be in the acceptable range. In some sandy and lighter soils pressures of 350 psi is recommended.
- Avoid running pressures exceeding 1000psi especially for extended periods. This may cause premature wear of the units and void your warranty.
- When setting pressure, it is normal to see the pressure gauge drop 150 – 200psi quickly and settle. This is because you are overloading the valve with oil and it will drain back to where you have set the valve. EG. If you have set the valve at 500psi it may build up to 700psi and when you let the remote go it will quickly settle back to 500psi.

Electric Valve

- Electric valve pressure is controlled by the dial on the control box in the cab. Adjust the dial and push the remote, this will build the pressure up to where it is set on the dial and divert the rest of the oil back to tank.
- **DO NOT** run electric or manual pressure valves in constant flow.

Manual Valve



Hex Head
Screw to adjust
down pressure

Electric Valve



MACHINE OPERATION/FIELD SET UP

- Ensure all hydraulic hoses have been correctly fitted.
- Ensure all primary breakaway couplers are correctly connected where necessary. (Tow behind models)
- Connect all electrical plugs.
- Power up monitor and run fan, walk around seeder to ensure air is getting to all units and there are no blockages. Turn fan off when you are happy with even air distribution.
- Calibrate product (it is recommended to use clean graded seed to prevent blockages or bridging).
- Once desired rate is achieved you can fill bins.
- Assess paddock to be planted for conditions and stubble/trash load.
- Set estimated down pressure.
- Adjust 4 row unit depth wheels to desired depth, drive forward 20m stop and check depth wheel is touching the surface. Try to turn the depth wheel, if the depth wheel can be turned with some resistance pressure is ok. If the depth wheel is not touching the surface more pressure will need to be applied. If you cannot turn the depth wheel excess pressure is being applied and will need to be reduced.
- Check correct depth directly behind the disc is being achieved, if not change position on the depth adjuster handle to achieve desired depth. Once desired depth and pressure are achieved set all row units to the same position ready to plant.
- Check press wheel behind the disc is pressing over the seed in the furrow. There are washers either side of the press wheel which can be swapped to achieve this.
- Check the rear cover wheel is closing the furrow correctly. If the ground is heavily compacted, you may need to swap spacers on the shaft to move the wheel closer to the furrow edge. There is also spring adjustment around the pivot at the top of the arm which can be tightened to press firmer. If you are in soft or sandy soil you may need to move the wheel further away from the furrow and reduce spring pressure. *Image Below: Press and Cover Wheel*

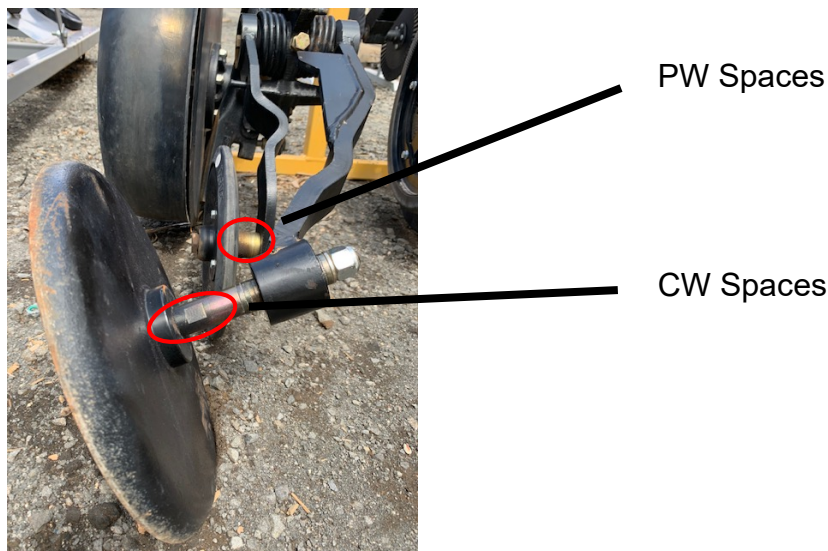

Lubrication

HI-TEC super red grease EP2 or equivalent recommended. Lubricate grease points shown below **between 80 and 100 working hours**. Shown below.
Apply recommended pumps of grease below to each to grease point.

Seeding Unit

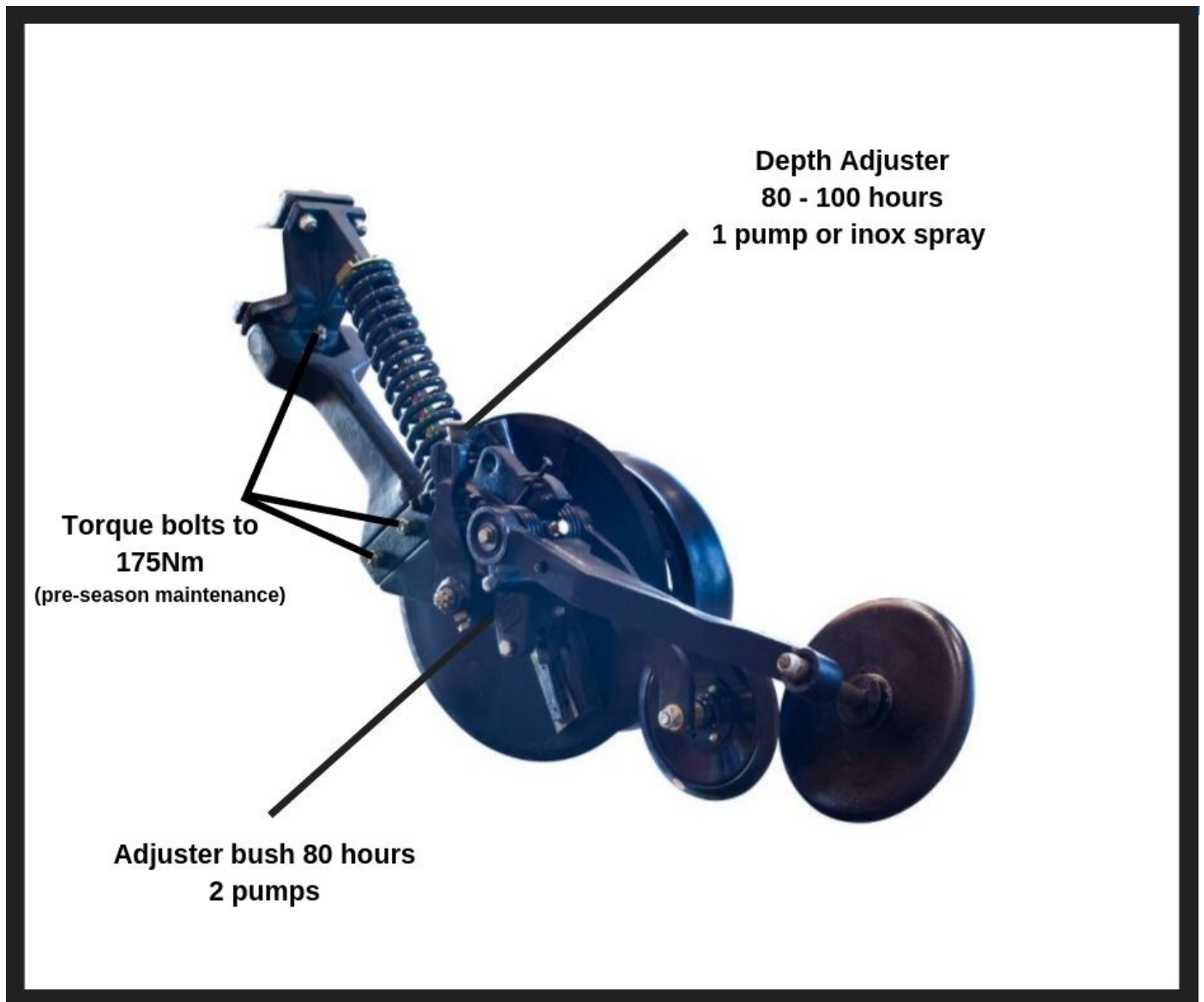

Grease Points

Grease all grease points shown on the pictures below.



- Grease every 20 hours – 5 pumps.
- Rolling bar should be set at a different position every greasing interval.



- Grease every 20 hours – 5 pumps.

Cont'd over page



- Grease every 20 hours – 5 pumps.
- Rolling bar should be set at a different position each greasing interval.

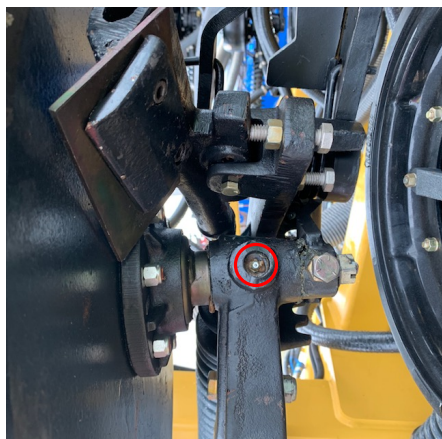

- When greased, the depth control handle should be rotated to distribute grease.
- Grease every 80-100 hours – 2 pumps.



- Only grease once per season – 5 pumps.
- Check pre-load of bearings on hub every 100 hours.
- Wheel nuts should be carefully checked after the first four hours of work then periodically. See page 25..

MAINTENANCE

Maintaining the Machine

- Protective gloves must be worn during assembly or changing of discs.
- If replacing components try to work in an area which is clean and dry.
- Never lubricate service or adjust machine while it is moving.
- Securely support all machine elements; these must be raised for service work.
- Always use a safety support when working on, under or around the machine.
- If support is not available, completely lower the wings and openers.
- Keep all parts in good condition and properly installed and fix any damage immediately.
- Replace worn or broken parts.
- Remove any build-up of stubble/soil or debris.
- Disconnect wiring harnesses from tractor before servicing electrical system components or welding on machine.
- Service tyres check wheels for correct pressure (see chart on page 26), cuts, bubbles, damaged rims or missing lugs. 40 psi – 2.7bar @ 30km.
- When inflating tyres, use a clip-on chuck and extension hose long enough to allow you to stand to one side and NOT in front of or over the tyre assembly. Use a safety cage if available.
- Check wheel nuts are tightened to correct specifications - See chart on page 25.
- When replacing a tyre ensure the machine is parked on a flat area with wings unfolded prior to removing.
- **Never weld or heat a wheel and tyre assembly.** The heat can cause an increase in air pressure resulting in a tyre explosion. Welding can structurally weaken or deform the wheel.
- If hydraulic hoses or cylinders have air in the system, bleed the system before use. If there is a failure in the hydraulic system, unsupported raised equipment could lower itself, causing serious personal injury or death.

IMPORTANT

- Tighten all bolts, U-bolts and cap screws **after 10 hours** of operation, and again at the end of the first week, or after **50 hours** of operation. All bolts are to be then tightened periodically.
- Checking bolts on machine are all part of GENERAL servicing and are responsible of the owner or operator.

Replacing Discs/Seed Boot Adjustment

Disc and seed boot adjustment are often overlooked, this can cause blockages in the field particularly in moist conditions where stubble/trash retention is high. Using a large 20" (510mm) x 6mm disc gives great wear life but some minor adjustments should be made as the disc wears down.

As the disc wears it is necessary to check the seed boot position. Because of the wear on the disc you are rolling the unit further forward exposing the seed boot and scraper closer to the soil/stubble and in some severe cases dragging the seed boot/scraper in the furrow.

This may have some adverse effects.

- Open the furrow further/more soil disturbance.
- Potential to bulldoze soil/stubble to the point it will build up between the seed boot and disc. This can cause the disc to stall and in some extreme cases long straw can partially cover the seed boot opening and effect seed placement or block the boot completely.
- Prematurely wear the scraper and scraper lock plate running in the soil.

To avoid these effects.

- Lift the seed boot 1 hole.
- Ensure the scraper is covering up to the disc hub to repel dirt/stubble from falling in behind the boot.
- We suggest the seed boot should be locked 5-6mm at the front of the boot away from the disc. Then adjust the scraper to be 1/2mm from the disc. Check seed placement as depending on furrow depth the seed boot may need to be shifted slightly in or out from this measurement.
- Replace the discs from 17" (430mm).

Disc Wear

Once discs are worn from 20" down to 17" they will require to be changed as they will not perform well in heavy stubble conditions. Excess wear will occur to seed boot and scraper. Operator will experience more blockages in damp soil conditions.



Effects of Worn Discs



Wheel Studs / Rims

Recommendations for Torque Settings and Inspection Intervals

Minimum Recommended Tension Intervals for Agricultural Wheels

	INITIAL FITMENT
RETENSION AT	4 HOURS OF OPERATION
	8 HOURS OF OPERATION
	24 HOURS OF OPERATION
	48 HOURS OF OPERATION

Alternatively, after the first 50km and subsequently every 100km, the stud bolt nuts are to be tightened by means of a dynamometric key and with the torque values listed below. Male and female treads are to be dry, however a small amount of anti-corrosive oil covering is permitted. Ongoing inspection and **retention** should be done in accordance with the daily wheel/tyre inspection procedures. These inspection periods may vary depending on vehicle operating conditions.

Recommended Torque Values for Axles

METRIC WHEEL STUDS

STUD SIZE	TORQUE
M12	75 ft.lbs (101 N.m)
M14	125 ft.lbs (169 N.m)
M16	175 ft.lbs (237 N.m)
M18	255 ft.lbs (345 N.m) – Common Sizes
M20	375 ft.lbs (508 N.m) – Common Sizes
M22	475 ft.lbs (644 N.m)
M24	565 ft.lbs (766 N.m)

IMPERIAL WHEEL STUDS

7/16"	60 ft.lbs (81 N.m)
1/2"	85 ft.lbs (115 N.m)
9/16"	135 ft.lbs (183 N.m)
5/8"	180 ft.lbs (244 N.m)
3/4"	295 ft.lbs (400 N.m)
7/8"	485 ft.lbs (657 N.m)

CLEANING & STORAGE

1. Wash the machine with pressure washer and store undercover on a level hard surface in a dry place. If storing outdoors, place a wooden board under the discs to prevent them from resting in the ground and rusting.
2. Use oil or diesel as anti-rust to coat discs, and then lower onto a wooden board.
3. Lubricate entire machine as specified in the lubrication section of this manual after washing.
4. Check for loose or damaged parts; replace and tighten as needed ready for next season.
5. Scratches should be re-painted as necessary to prevent rust.
6. Make sure no fertiliser or seed debris is on the machine, as they are treated with chemicals that could damage the machine paint and rubber hoses.
7. It is recommended to drain a small amount of oil from the hydraulic hoses when disconnecting the seeder from the tractor. By draining 60ml from the hoses will reduce the opportunity of pressure build up in the hoses which will prevent seal damage

TYRES

Standard – 400/60 x 15.5 OR 500/45 x 22.5

Speed	1.6 bar (23 PSI)	1.8 bar (26 PSI)	2.0 bar (29 PSI)	2.2 bar (32 PSI)	2.4 bar (35 PSI)	2.6 bar (38 PSI)	2.8 bar (41 PSI)	3.0 bar (44 PSI)	3.2 bar (46 PSI)	3.4 bar (49 PSI)	3.6 bar (52 PSI)	3.8 bar (55 PSI)	4.0 bar (58 PSI)	4.1 bar (59 PSI)	62psi	65psi	68psi
50 FR	1625	2070	2380	2700	2995	3285	3555	3825	4105	4390	4650						
40 FR	1805	2300	2645	3000	3325	3650	3950	4250	4565	4875	5165						
10 FR	2380	2980	3390	3820	4240	4635	5030	5415	5770	6140	6515						
10 C	2225	2715	3040	3365	3690	4015	4335	4650	4965	5260	5560	5860	6155	6465	6780	7075	7375



GASON VRT HYDRAULIC DRIVE METERING SYSTEM WITH FARMSCAN AG 7500 MONITOR

Software Version 2.16.06

Calibration Procedure.

1. Change meterbox settings to suit product being sown.
 - Low application rates (below 15 kg/ha)
 - fit metershaft sleeves/restrictor plates (refer manual).
 - use low sprocket ratio drive.
 - Medium to High application rates (above 15kg/ha)
 - Select either low or high ratio sprocket drive (refer manual).
2. Place at least 2 bags of the appropriate product in the bin being calibrated.
3. Disengage fan by shutting off flow at the flow control valve located next to the fan. Rotate the handle anti-clockwise to shut off.



4. Now turn monitor on at the tractor.

5. Select new Job (paddock) or reset a previously used one. This can be done by entering 'Jobs Menu' via the 'Setting Menu' screen. Refer to the Farmscan Ag 7500 operators' manual for further details.



Figure 2. Main Operating screen set up for 2 Bin



Figure 3 'Setting Menu' screen

6. Calibrate seeder meterbox's for product to be sown from the 'Setup Menu' (Refer Fig. 4,5 & 6) :-

- a) Select bin to calibrate (1,2 or others)
- b) Input application rate (eg. 60 kg/ha).
- c) Input increment steps (eg. 5 kg/ha).
- d) Select product for that bin (WHEAT B1) or create a new product name.
- e) Add product details such a Bulk Density (Optional).
- f) Calibrate product to determine calibration 'Factor' (pulse/kg)

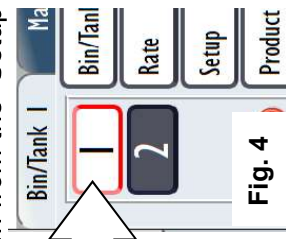

WARNING! SWITCH TRACTOR OFF BEFORE WORKING ON THE SEEDER'S METERING SYSTEM, METERSHAFT AND MOTORS COULD TURN AT ANYTIME.

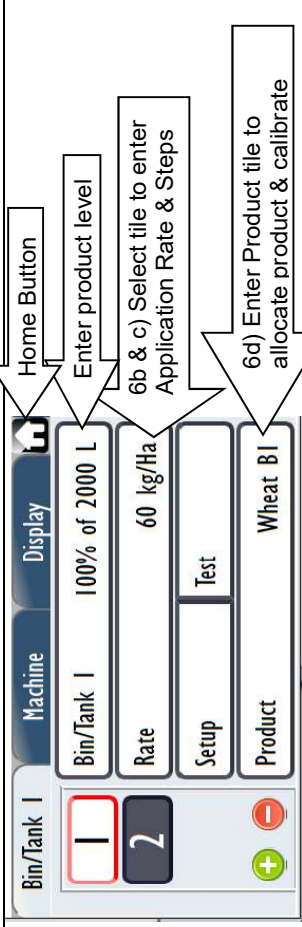

Figure 5 'Bin/Tank' screen

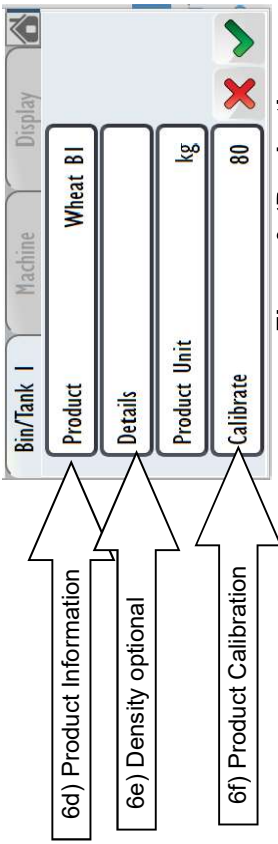

Figure 6 'Product' screen

7. Preparing to run a product calibration test:-

a) If setting up a new product with no previous calibration 'Factor', enter a manual factor of 80 to allow the system to operate.

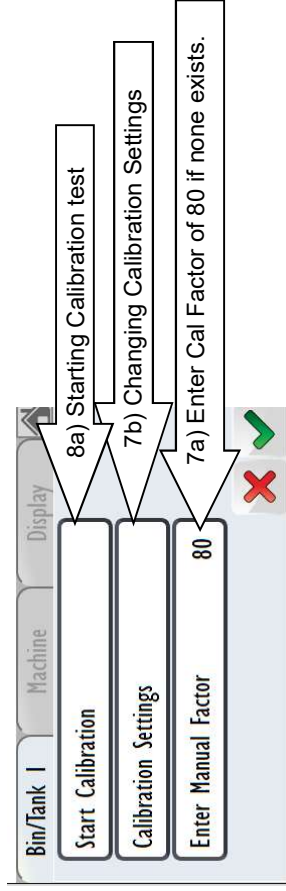

Figure 7 'Calibrate' screen

b) If bin has not previously been calibrated, enter the 'Calibration Settings' (refer Fig. 7) to check settings suit your requirements. It is possible to select either 'Weight', 'Count' or 'Time' (refer Fig.8) as the Calibration Method. In most cases selecting Weight is the preferred setting where you will be asked to enter a desired sample weight to be metered. 'Calibration Rate' should reflect actual paddock rate and 'Simulation Speed' set to your average seeding speed.

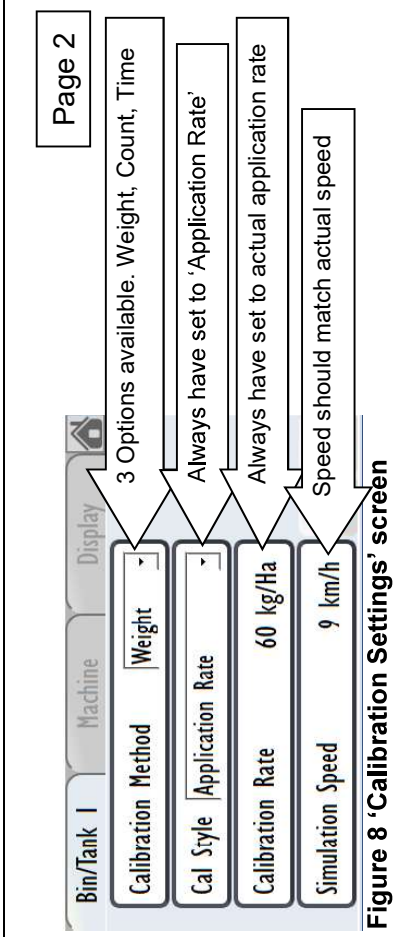

Figure 8 'Calibration Settings' screen

NOTE: The most accurate calibration results will be achieved if settings simulate actual in paddock conditions.

8. Starting the Calibration test (refer Fig. 7 & 9):-

a) Enter the Calibration process by pressing 'Start Calibration' (Fig. 7).
 b) Enter the weight in kg's you wish to collect during the calibration. Depending on your product type, 0.5kg for small seeds in the pasture planter and 2 - 4kg's for cereal and fertilizer in the main bins.

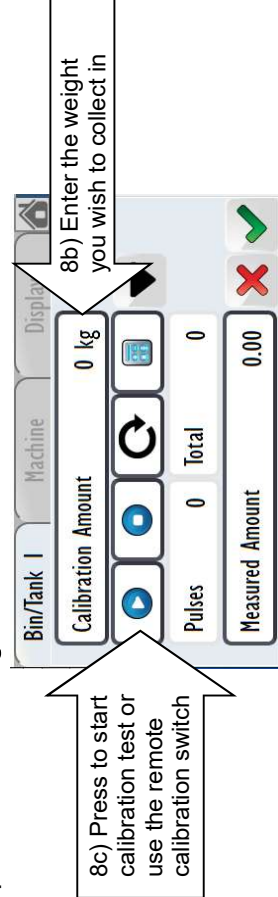

Figure 9 'Start Calibration' screen

c) With the seeder prepared, tractors hydraulics engaged, fan turned off at the seeder, calibration tray fitted to the meterbox and meterwheel's primed, you can either start the metering system at the monitor by pressing the start button or go to the seeder and press the remote calibration button (Fig.10).

Pressing once to start the calibration. Pressing a second time will stop the hyd. motor. This can be useful if the tray overflows.



Fig. 10

9. Entering the sample weight (Refer Fig.10):-

Weigh sample of product on scales supplied. If there is any concern about how reliable the sample test was, run the test again. You can run several tests from the seeder before entering a weight by using the calibration button at the seeder to stop and restart tests.

NOTE:- It is the responsibility of the operator to check the accuracy of the scales on a regular basis. Uncertified test weight supplied.

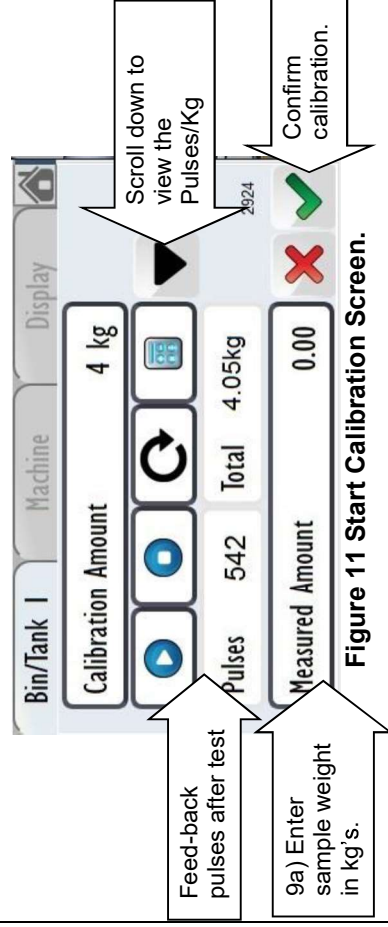

Figure 11 Start Calibration Screen.

- a) Enter the sample weight into the 'Measured Amount' tile.
- b) You will be asked to confirm that there was a change in the Pulse per kg rate. Press 'Ok' to accept.

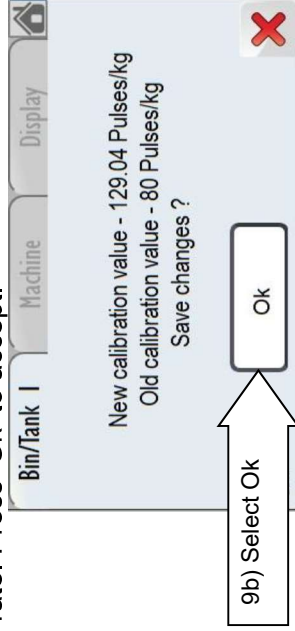

Fig. 12

You can continue with more calibration tests if you wish by repeating the process or leave the calibration area altogether by selecting the green tick & home button. Repeat the process for all bins being used.

Note: If a product has previously been calibrated, the pulses/kg figure will already be assigned to that product. Gason's recommend that the operator should always confirm that this previous figure is still relevant for the particular seed/fertiliser batch and bulk density.

- 10. When all of the bins have been calibrated return to the main operating screen.

- 11. Ensure that all the information displayed on the main page is correct. Bins should show the correct application rates. Reset the 'Load Applied' and 'Job Applied' area totals by touching the tile and using the reset function.

- 12. Re-engage the fan's flow control valve by turning the valve.

- 13. Start the fan by engaging the tractor's remote system. Check and alter the fan speed if required at the tractor if closed centre hydraulics or at the seeder's flow control valve if open centre hydraulics.

- 14. To begin seeding operation simply push the RUN/HOLD tile or press the button on the optional remote switch in the cab if fitted.

Brief Trouble Shooting Guide:- (Refer to the Monitor manual for more information).

Reason's why the Monitor will not come off Hold:-

- a) Fan has not been engaged or is running below the low fan alarm.
- b) Main harness not connected or not responding. Check connections.
- c) No ground speed is being detected at the seeder. Check display and sensor distance to target on drive speed wheel.

Reason's why a particular bin does not start:-

- a) Bin is switched off.
- b) Bin is not calibrated.
- c) Monitor has lost vital settings or is not communicating with the Unipod.

Reason's why the desired application rate may not be obtained:-

- a) Ground speed too fast.
- b) Sprocket ratio needs to be changed. This occurs on the right-hand side of the meterbox. **WARNING!** Switch tractor off before working on the seeder's metering system. Metershaft and motors could turn at anytime.
- c) Meterwheel sleeves may still be in place, restricting max. output.
- d) Check meterwheel's are not clogged with material.

General checklist before operation:-

- a) Sowing width has been recorded in the 'Machine' / 'Measurement' page.
 - b) The correct wheel factor has also been recorded on the 'Machine' / 'Speed-GPS' / 'Wheel Sensor' / 'Calibration' / 'm/Pulses' page. This may vary depending on the ground being sown. It is advisable to perform your own test to check the preset value. Refer Air Seeder Operator's manual or Farmscan Ag monitor manual for further details.
 - c) Alarms are functional and have their correct preset values.
- FAN speed alarms, low and high, should be set (refer below).
-BIN sensors should be enabled for all active bins (p/planter not included).

Typical use of Screens/Tiles for a 2 Bin Seeder

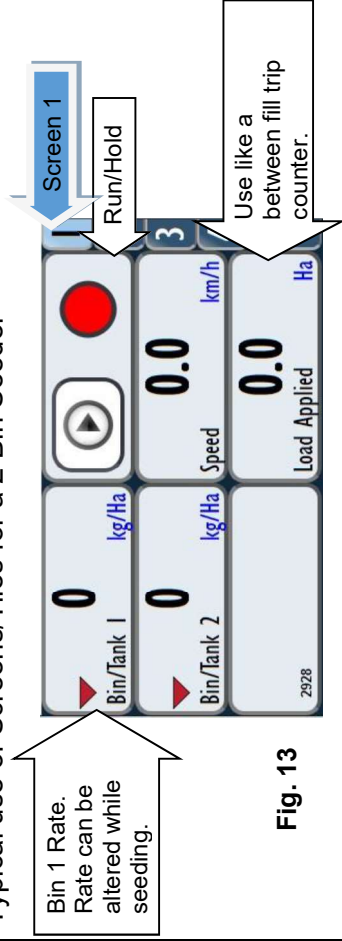

Fig. 13

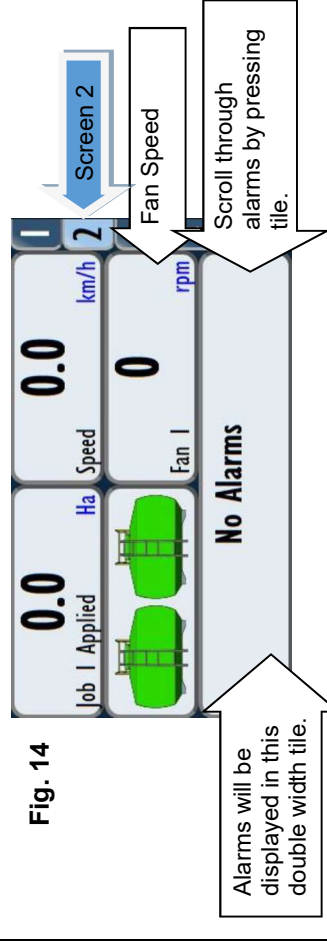

Fig. 14

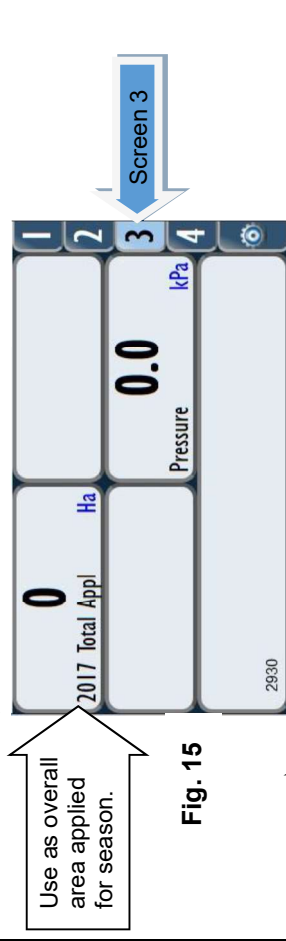

Fig. 15

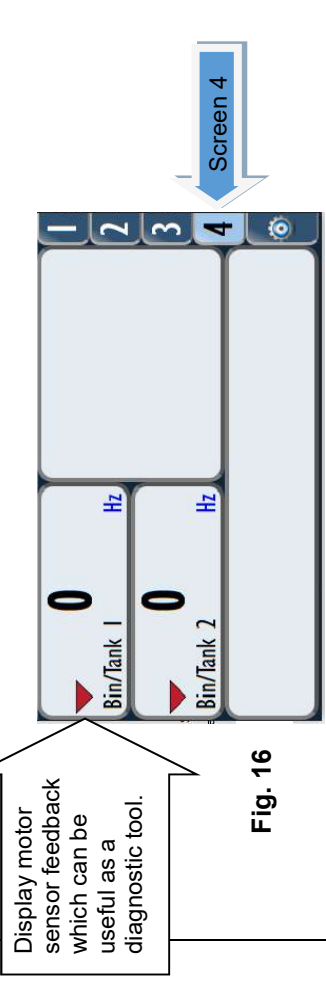

Fig. 16

Typical Factory Monitor Settings:-
 'Bin/Tank'-Setup-'Control Output' PWMVolt
 'Maximum' varies between 6-8 volts
 'Minimum' varies between 1.8-2.2 volts
 'Advanced Settings' Span 50%
 Dead Band 0.5%
 Time constant 3s

Implement width:-

'Machine'-Measurements-'Width' ~ operator set
 Prime Function:-

'Machine'-Control Speeds'- Minimum Speed 2km/h
 Slow Hold Speed 4km/h
 Enable Prime ticked
 Prime Time Mode Set Time (Constant)
 Prime Time 5s
 Prime Speed 7km/h

Bin Level Function:-

'Machine'-Auxiliary Setup'- #1:POD#1 Bin/Tank 1 Level Input
 #2:POD#1 Bin/Tank 2 Level Input
 #3:POD#1 Bin/Tank 3 Level Input



Fan Speed Sensor:-

'Machine'-Fan Setup'- 'No. of Fans' 1

'Fan 1 Setup' 'Sensor Type' AA-112C/P
 'Pulse/Revolutions' 1

Air Pressure Sensor:-

'Machine'-Pressure Sensor'- 'Pressure Sensor #' 1
 'Select Type' 2080

Alarm Settings:-

'Low Fan 1-RPM'-Critical-Run Only-Manual Reset-Minimum 2600rpm
 'High Fan 1- RPM'-Normal-Always-Automatic-Maximum 4550rpm
 'Bin # Rate-%'-Normal-Run Only-Automatic-Maximum 10%
 'Bin # Level Low-T/F'-Normal-Always-Automatic-T/F
 'Bin # Shaft Stopped-T/F'-Critical-Run Only-Manual Reset-T/F

For Further information:-

Refer to the Farmscan Ag 7500 Seed Rate Controller Operators Manual. Comprehensive instructions are in the manual regarding all aspects of the various monitor's features.

TROUBLESHOOTING

PROBLEM	POSSIBLE CAUSE	POSSIBLE REPAIR
Plant Misses No seed in Slot	Air leaks on bin lids or metering box Blocked seed boot Blocked hoses	Fan speed Check airflow at base of seed boot and clean if necessary – check seed hoses
Plant Multiples	Bridging in seed box Bridging in seed boot Kinked hoses	Seed not graded. Need to fit ½ plate over meter rollers to improve seed flow. Ensure hoses are free flowing to the boot, check for crushed/pinched hoses around fold areas and replace if necessary.
Seed out of furrow	Excess air speed (seed bounces) Seed boot too far away and/or too close to disc Press wheel picking up seed Seed boot partially blocked at bottom of boot with soil Thick stubble causing hair pinning	Reduce air speed or fit diffusers if this cannot be achieved. Adjust seed boot to be 5-6mm away from disc at the front of the seed boot. Then adjust scraper to just miss the disc Conditions may be too wet. May need to lift seed boot 1 position to be away from the soil. Clean seed boot. Need to set depth deeper to achieve soil/seed contact.
Units Bulldozing Trash/dirt building up	Too much hydraulic down pressure (units may lift wheels off the ground)	Reduce pressure to a point you can almost turn depth wheels by hand. (Optimum pressure 500psi) Sandy soils down to 350 psi
	Unit bar too high (units need to lay back to allow trash to run through)	Reduce pressure until centre of roll bar is approximately 660mm from the ground
	Seed boot too low Excess disc wear Disc worn below 17"	When discs wear the unit has to roll around further and will not allow trash to flow through, this also exposes the bottom of seed boot to soil and trash build up.
Poor disc penetration	Worn blunt discs Hard soil conditions Depth wheel not adjusted correctly	Raise unit pressure (avoid using pressure 1000psi & above for long periods as unit damage may occur)
	Deep stubble	You may need to use deeper setting than usual on the unit, this will also help with hair-pinning. (Seed left on top of ground)

	Excess disc wear	Replace discs if close to 17"
Cover wheels not closing or throwing too much soil or lifting seed from slot	Cover wheel too far away from furrow	Remove spacers to get desired fill. Soil conditions may vary. Eg: Sandy soil requires less spring pressure & further away from slot. Dry clay soil, more spring pressure required and closer to furrow
		Less spring pressure, too close to furrow, excess ground speed (9-10km/h).
Stubble & dirt build up between disc & seed boot	Seed boot & scraper too far away from disc.	Set Seed boot approximately 5-6mm at the front of the boot to the disc & scraper. 1/2-1mm from disc
	Stubble & soil may be too wet.	In heavy dew/ fog conditions you may need to wait until it dries a little
	Large amounts of stubble & or trash.	Use seed boot on highest setting
	Too much hydraulic pressure same as bulldozing	Reduce pressure if possible
Uneven seed placement. Seed on top of ground	Seed boots worn running in soil & partially blocking	Check seed boot height & disc wear.
	Too much ground speed. (disc may grab seed & soil & throw)	Reduce speed to approx. 9 kms/hr
	Too much air, seed bouncing out.	Reduce fan pressure.
	Not enough air.	Increase air if hoses are curved/bent so they don't build up and with enough vibration all fall to seed boot together.
	Heavy stubble	Set depth deeper than usual to allow seed to fall into furrow.
	Seed boot incorrectly adjusted	Too far away from disc.
	Too far away from discs.	Adjust seed boot to 5-6mm & the front of the boot to disc.

Serafin ULTISOW

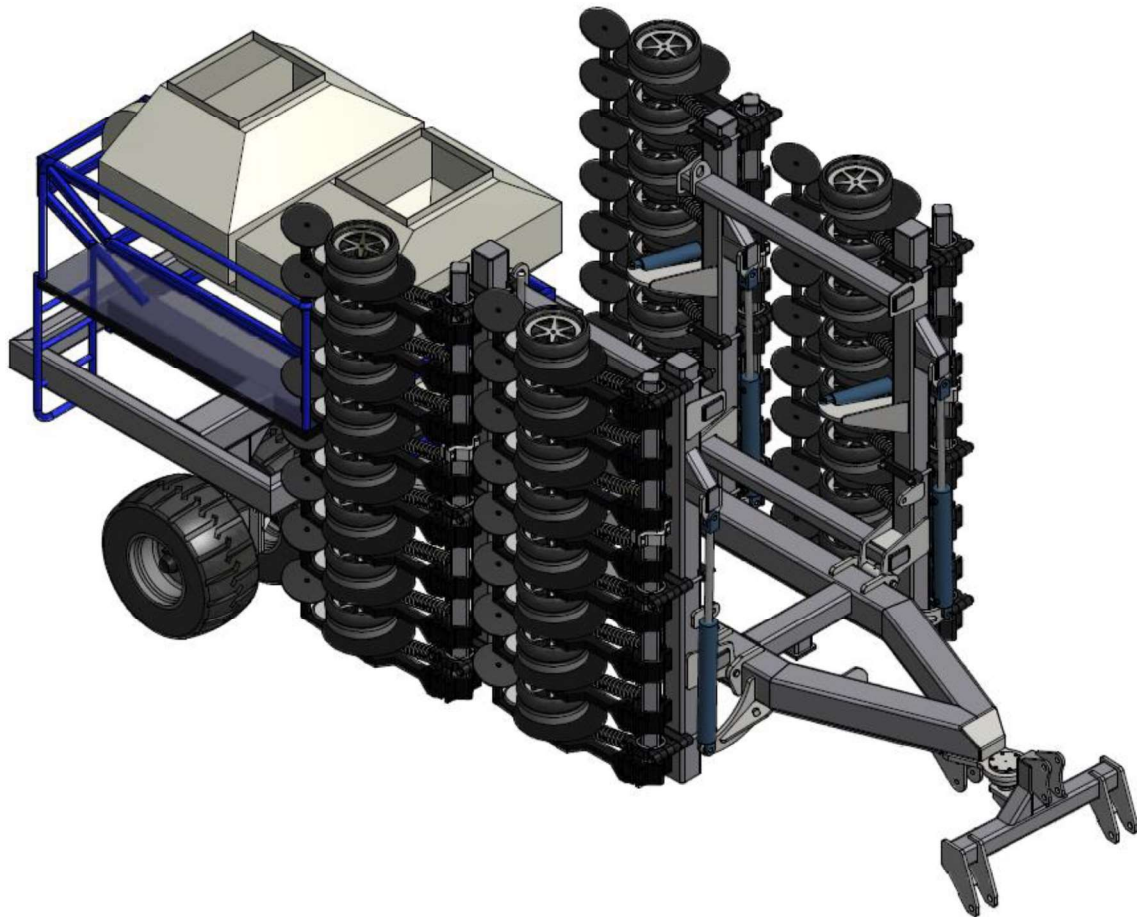

Narrow Fold Range

PARTS CATALOGUE

Left Hand Side Row Unit

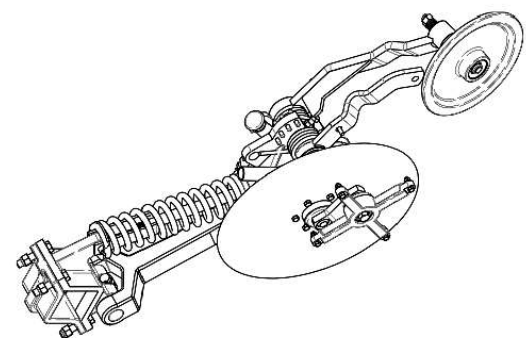
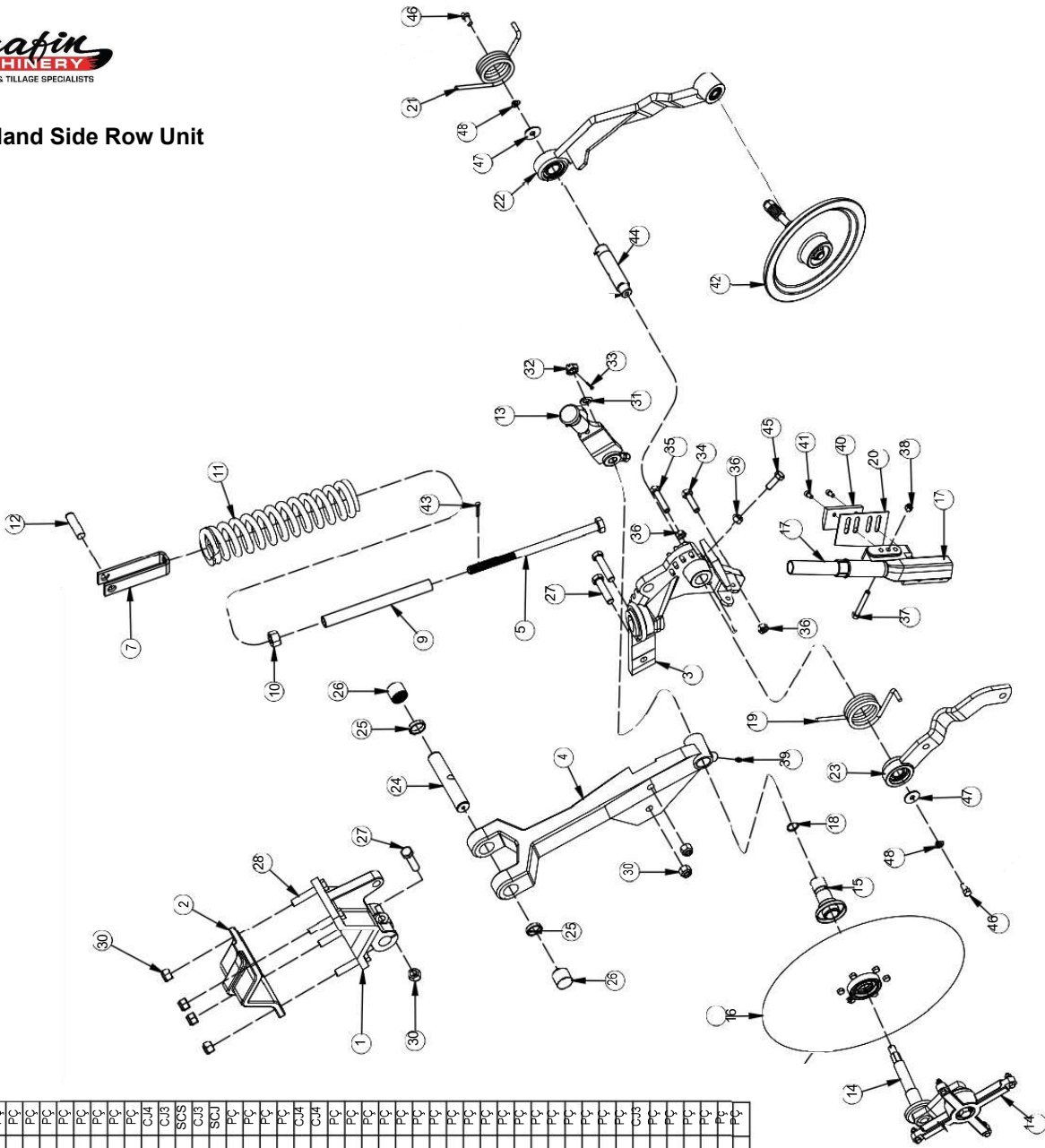

Item	Quantity	Code	Product Description	PCS
1	1	BAL52520100229	CLAMP BOTTOM PIVOT ROW UNIT SD/SB	PC
2	1	BAL52520101772	CLAMP TOP PIVOT ROW UNIT	PC
3	1	BAL55300152944	SUPPORT OF COMPRESSION WHEELS LH	PC
4	1	BAL53260700142	ARM ROW UNIT MAIN LH	PC
5	1	BAL54200100566	BOLT ROW UNIT MAIN SPRING	PC
6	1	BAL50240100077	WASHER FLAT 20.3 X 46.5 X 4.75MM	PC
7	1	BAL5530200919	BRACKET U- MAIN SPRING SUPPORT	PC
8	1	BAL50240102908	WASHER SPECIAL 85X40 MAIN SPRING	PC
9	1	BAL51081102140	TUBE 26.9X21.6X275.5 MM MAIN SPRING	PC
10	1	BAL60203107709	NUT HEX 3/4" UNC CH 1.7-32"	PC
11	1	BAL54000101187	SPRING MAIN COMPRESSION 62X91X375MM	PC
12	1	BAL5432092760	PIN MAIN SPRING 3/4"X20MM	PC
13	1	BAL54840101471	DEPTH ADJUSTER ARM LH COMPLETE	C/J
14	1	BAL52040104844	LEVER AXLE ASSY COMPLETE LH	C/J3
15	1	BAL52320115361	BUSH AUXILIARY	SCS
16	1	BAL52040105514	DISC FLAT 20" X 6MM COMP. W/ HUB	C/J3
17	1	BAL50520100676	SEED BOOT LH SB2019	SCJ
18	1	BAL60200100240	ORING AUX BUSH 2-119-23.47X2.62MM	PC
19	1	BAL54000101047	SPRING TORSION RT 67X84X45MM 8.5MM WIRE	PC
20	1	BAL55200100760	SCRAPER DISC ADJUSTABLE 4 SLOTS	PC
21	1	BAL54000101055	SPRING TORSION LH 67X84X45MM 8.5 WIRE	PC
22	1	BAL55300152960	COVER WH ARM LH COMP. W/ BEARINGS	C/J4
23	1	BAL55300152952	PRESS WHEEL ARM RH COMP. W/ BEARINGS	C/J4
24	1	BAL5432092827	PIN ROW UNIT MAIN PIVOT	PC
25	2	BAL60200100010	ORING MAIN ROW PIVOT SEAL	PC
26	2	BAL60203500036	BEARING CSN-2020	PC
27	2	BAL60203104351	BOLT HEX UNF 5/8" X 2-3/4" ALT. NFB88X234	PC
28	2	BAL60203104366	BOLT HEX 5/8" X 3-1/4" UNF	PC
29	3	BAL60203111471	BOLT HEX 5/8" X 3" UNF	PC
30	7	BAL60203107610	NUT NYLOC UNF 5/8" ALT. NFN65	PC
31	1	BAL50240101545	WASHER FLAT 16X29X3.00MM ALT. FWM16	PC
32	1	BAL60203108357	NUT 5/8" HEX CASTLE	PC
33	1	BAL60200501015	SPLIT PIN 1/8" X 1" ALT. C1152-7	PC
34	1	BAL60203108934	BOLT HEX BSW 1/2" X 2"	PC
35	1	BAL60203112044	BOLT HEX BSW 1/2" X 2-1/2"	PC
36	3	BAL60203107663	NUT HEX BSW 1/2" ALT. BSWM12	PC
37	1	BAL60203100674	BOLT UNC 3/8" X 3" ALT. NCB38X300	PC
38	1	BAL60203108403	NUT UNC NYLOC 3/8" ALT. NCBN38	PC
39	1	BAL60201301001	GREASE NIPPLE UNF 1/4"	PC
40	1	BAL6460100276	SCRAPER PLATE	PC
41	2	BAL60203101948	SCREW ALLEN HEAD 5/16" X 5/8"	PC
42	1	BAL52600100629	COVER WHEEL COMPLETE SB SERIES	C/J3
43	1	BAL60200501147	SPLIT PIN 1/4" X 1-1/2" ALT. CPS80350	PC
44	1	BAL5232015396	SHAFT COMPRESSION WHEELS SUPPORT	PC
45	1	BAL60203120012	BOLT BSW 1/2" X 1-1/2" ALT. BSW12X112	PC
46	2	BAL60203109906	BOLT UNC 7/16" X 7/8" ALT. NCB716X78	PC
47	2	BAL50240106555	WASHER COMPRESSION WHEEL ARMS	PC
48	2	BAL60200104065	WASHER SPRING 7/16" ALT. 3W716	PC

**Right Hand Side
Row Unit**

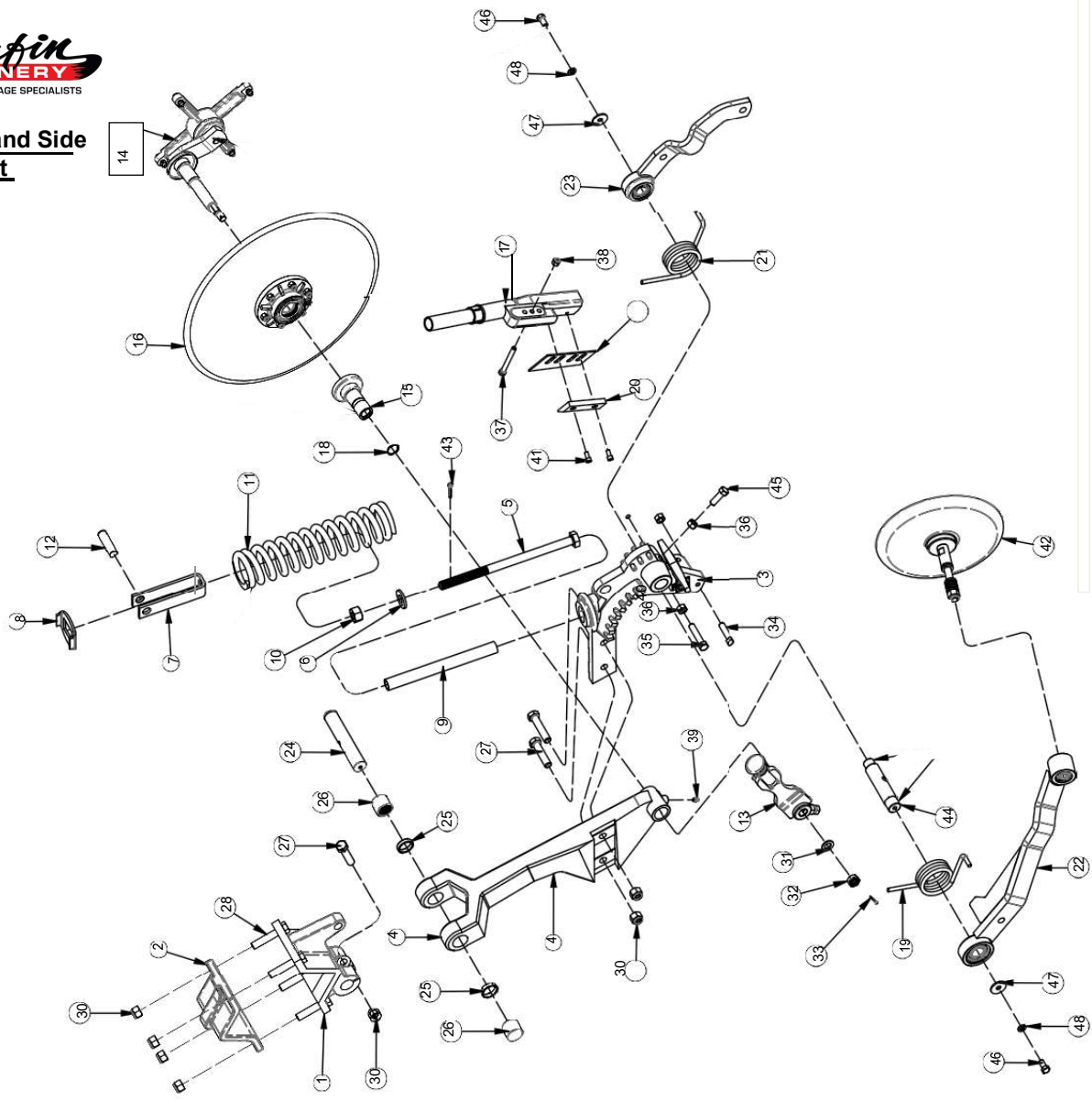

Item	Quantity	Code	Product Description	PCS
1	1	BAL52520100228	CLAMP BOTTOM PIVOT ROW UNIT SD/SB	PC
2	1	BAL52530101772	CLAMP TOP PIVOT ROW UNIT	PC
3	1	BAL5330152671	SUPPORT OF COMPRESSION WHEELS RH	PC
4	1	BAL53360700150	ARM ROW UNIT MAIN RH	PC
5	1	BAL5420100868	BOLT ROW UNIT MAIN SPRING	PC
6	1	BAL52440100077	WASHER FLAT 20.3 X 46.5 X4.75MM	PC
7	1	BAL53042009919	BRACKET U - MAIN SPRING SUPPORT	PC
8	1	BAL5240102908	WASHER SPECIAL 85X40 MAIN SPRING	PC
9	1	BAL51081102140	TUBE 26.9X21.6X275.5MM MAIN SPRING	PC
10	1	BAL62033107309	NUT HEX 3/4" UNC CH 1.7/32"	PC
11	1	BAL5400101187	SPRING MAIN COMPRESSION 62X91X3.75MM	PC
12	1	BAL54352092750	PIN MAIN SPRING 3/4" X 70MM	PC
13	1	BAL54840101501	DEPTH ADJUSTER ARM RH COMPLETE	CL4
14	1	BAL52040104852	LEVER AXLE ASSY COMPLETE RH	CJ3
15	1	BAL52320115361	BUSH AUXILIARY	SCS
16	1	BAL5240105814	DISC PLAT 20" X 6MM COMP. WI- HUB	CJ3
17	1	BAL5620100668	SEED BOOT RH 582019	SCU
18	1	BAL62030100240	ORING AUX BUSH 2"118 23.47X2.62MM	PC
19	1	BAL6400101697	SPRING TORSION RH 67X84X45MM 1.8 5MM WIRE	PC
20	1	BAL5320100750	SCRAPER DISC ADJUSTABLE 4 SLOTS	PC
21	1	BAL5400101059	SPRING TORSION LH 67X84X45MM 1.8 5 WIRE	PC
22	1	BAL5300152852	COVER WH ARM LH COMP WI- BEARINGS	CL4
23	1	BAL543202927	PIN ROW UNIT MAIN PIVOT	SC4
24	1	BAL6200100010	ORING MAIN ROW PIVOT SEAL	PC
25	2	BAL6203300036	BEARING CSN-2020	PC
26	2	BAL6203304351	BOLT HEX UNF 5/8" X 2.34" ALT. NFB58X234	PC
27	2	BAL6203304361	BOLT HEX 5/8" X 3-7/4" UNF	PC
28	2	BAL6203304386	BOLT HEX 5/8" X 3-7/4" UNF	PC
29	3	BAL6203311471	BOLT HEX UNF 5/8" X 2.34" ALT. NFB58X234	PC
30	7	BAL6203307610	NUT NYLOC UNF 5/8" ALT. NFN68	PC
31	1	BAL6203308357	WASHER FLAT 16X29X3.00MM ALT FWM16	PC
32	1	BAL6203308357	NUT 5/8" HEX CASTLE	PC
33	1	BAL6203308357	SPLIT PIN 1/8" X 1" ALT C1152-7	PC
34	1	BAL6203308357	NUT 5/8" HEX CASTLE	PC
35	1	BAL6203312344	BOLT HEX BSW 1/2" X 2-1/2"	PC
36	3	BAL6203307563	NUT HEX BSW 1/2" ALT BSW12	PC
37	1	BAL6203308674	BOLT UNC NYLOC 3/8" ALT NCONN38	PC
38	1	BAL6203308403	NUT UNC NYLOC 3/8" ALT NCONN38	PC
39	1	BAL6201301001	GREASE NIPPLE UNF 1/4"	PC
40	1	BAL54640100276	SCRAPER PLATE	PC
41	2	BAL6203301948	SCREW ALLEN HEAD 5/16" X 5/8"	PC
42	1	BAL6203300628	COVER WHEEL COMPLETE SB SERIES	PC
43	1	BAL6203309147	SPLIT PIN 1/4" X 1-1/2" ALT. CPS60350	CL3
44	1	BAL6203315366	SHAFT COMPRESSION WHEELS SUPPORT	PC
45	1	BAL62033120012	BOLT BSW 1/2" X 1-1/2" ALT. BSW12X112	PC
46	2	BAL6203309906	BOLT UNC 7/16" X 7/8" ALT. NCB716X78	PC
47	2	BAL62040106555	WASHER COMPRESSION WHEEL ARMS	PC
48	2	BAL62033040383	WASHER SPRING 7/16" ALT. SW716	PC

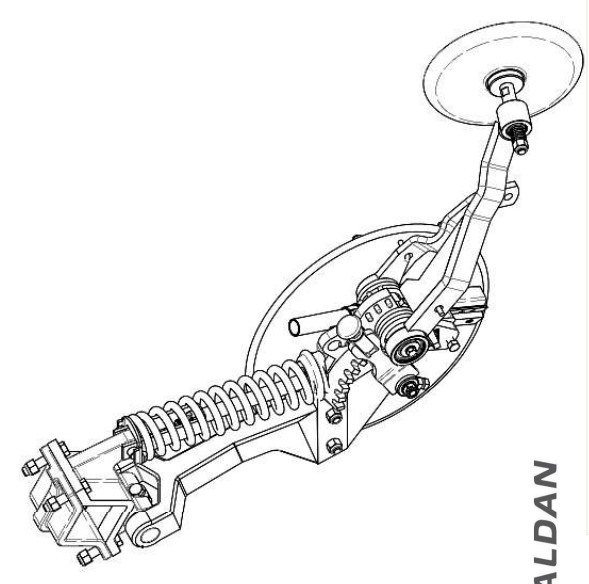

Disc and Hub Complete

Part Number: 5204010551-4

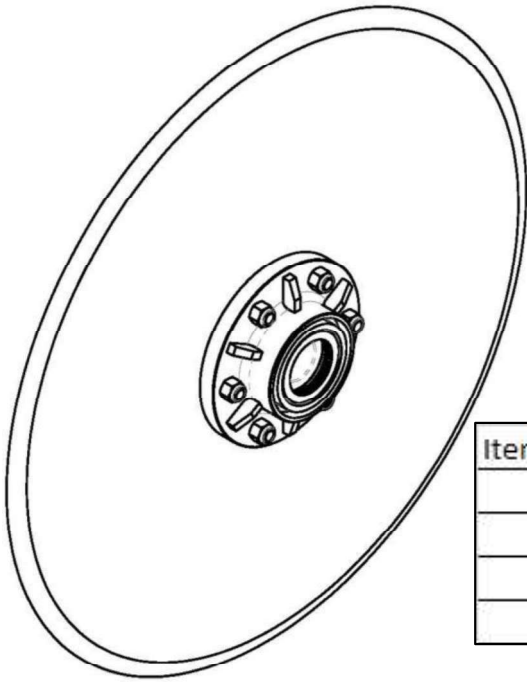

Item No	Qty	Part No	Description
1	1	BAL52040105522	DISC HUB COMP. SB2019
2	1	BAL28634374096	DISC 20"X6MM SINGLE BEVEL
3	6	BAL60203108403	NUT UNC NYLOC 3/8" ALT NCNN38
4	6	BAL60203100267	BOLT UNC 3/8" X 1-1/4"

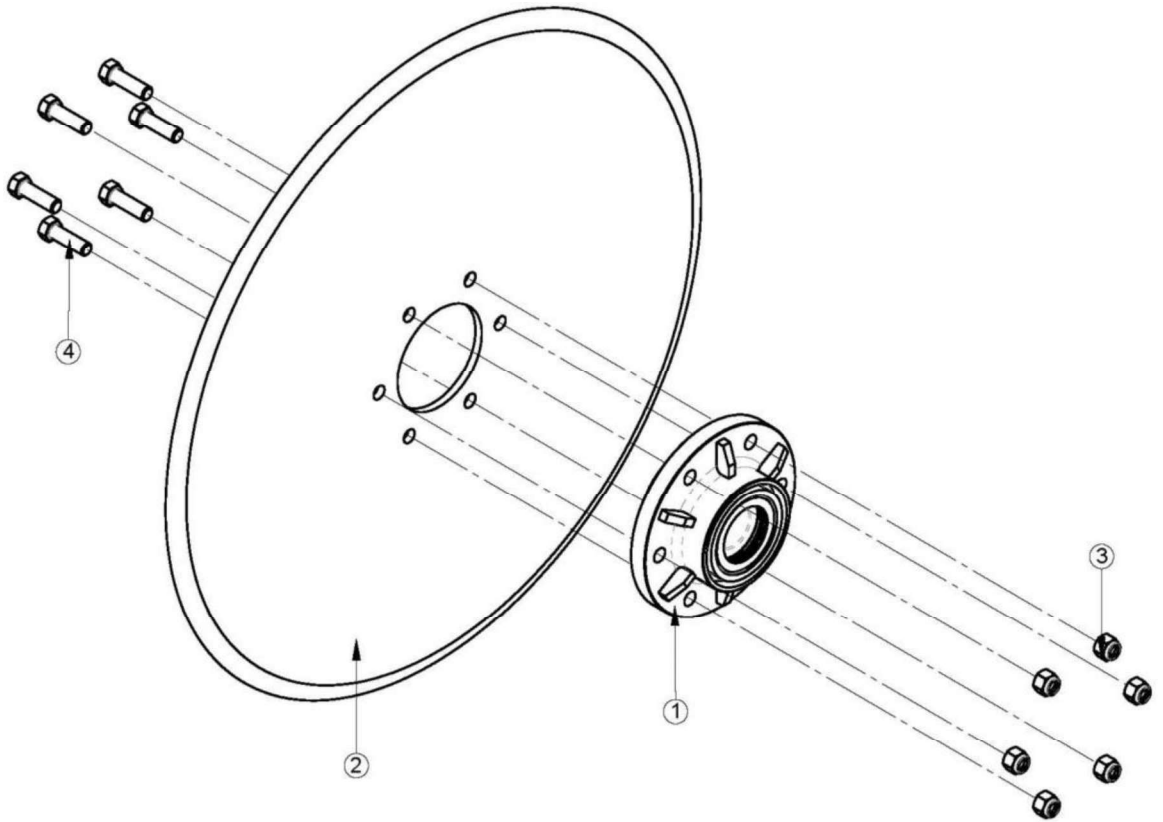

Disc and Hub Bearing

Part Number: 5204010552-2

Item No	Qty	Part No	Description
1	1	BAL52040105506	DISC HUB SB2019
2	1	BAL60203509700	SEAL 36X60X9,5 SB2019 DISC HUB
3	1	BAL60203502764	SEAL 40 X 58 X 8 - 18-20" DISC
4	1	BAL60200103273	CIRCLIP INTERNAL ALT IC060
5	1	GREG281813	BEARING SB2019 DISC HUB

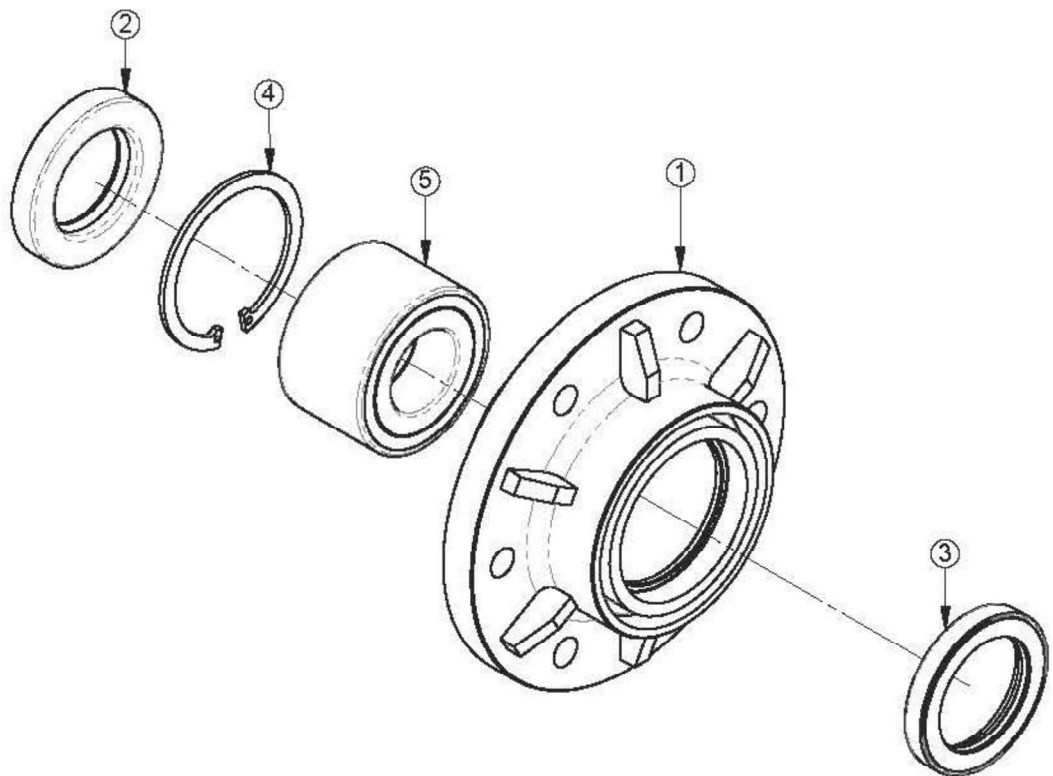
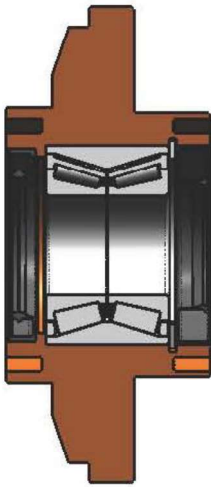

Complete Depth Wheel Assy Left Hand

Part Number: 5498010201-0

Item No	Qty	Part No	Description
1	1	BAL54840101803	LEVER AXLE LH SB2019
2	1	BAL52040104828	DEPTH WHEEL HUB COMP SB2019
3	1	BAL60203102936	BOLT 5/8" X 2-3/4" LH SB2019 DW
4	1	BAL50800113137	BUSH INTERNAL DEPTH WHEEL SB2013-19
5	4	BAL50203100380	BOLT 5/16" X 1"
6	8	BAL60203120209	BOLT 5/16" X 3/4"
7	12	BAL60203107440	NUT NC 5/16"
8	1	BUC10067TYRE	DEPTH WHEEL TYRE 15" X 4.5"
9	2	BUC30067SE	RIM BUCO TO SUIT BUCO DW TYRE
10	12	BAL60200104040	WASHER SPRING 5/16
11	1	BAL50960100317	DEPTH WHEEL DUST PLATE
12	8	BAL50240100590	SHIM DEPTH WHEEL SPACER SD/SB SERIES
13	1	BAL50800113145	BUSH DEPTH WHEEL SPACER SB2013-19

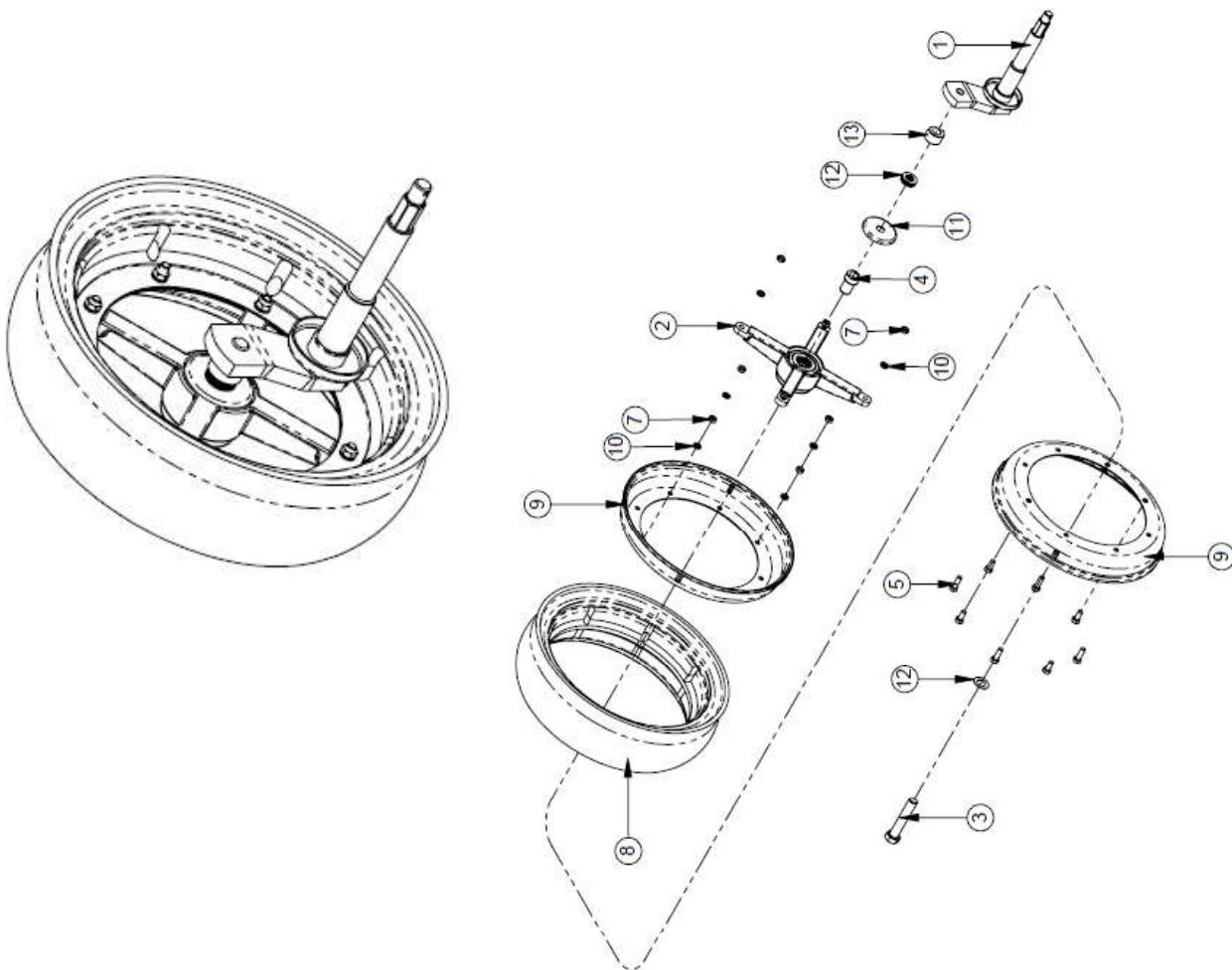

Complete Depth Wheel Assy Right Hand

Part Number: 54840102019R

Item No.	Qty	Part No	Description
1	1	BAL54840101790	LEVER AXLE RH SB2019
2	1	BAL52040104828	DEPTH WHEEL HUB COMP SB2019
3	1	BAL60203102928	BOLT 5/8" X 2-3/4" RH SB2019 DW
4	1	BAL50800113137	BUSH INTERNAL DEPTH WHEEL SB2013-19
5	4	BAL50203100380	BOLT 5/16" X 1"
6	8	BAL60203120209	BOLT 5/16" X 3/4"
7	12	BAL60203107440	NUT NC 5/16"
8	1	BUC10067TYRE	DEPTH WHEEL TYRE 15" X 4.5"
9	2	BUC30067SE	RIM BUCO TO SUIT BUCO DW TYRE
10	12	BAL60200104040	WASHER SPRING 5/16
11	1	BAL50960100317	DEPTH WHEEL DUST PLATE
12	8	BAL50240100590	SHIM DEPTH WHEEL SPACER SD/SB SERIES
13	1	BAL50800113145	BUSH DEPTH WHEEL SPACER SB2013-19

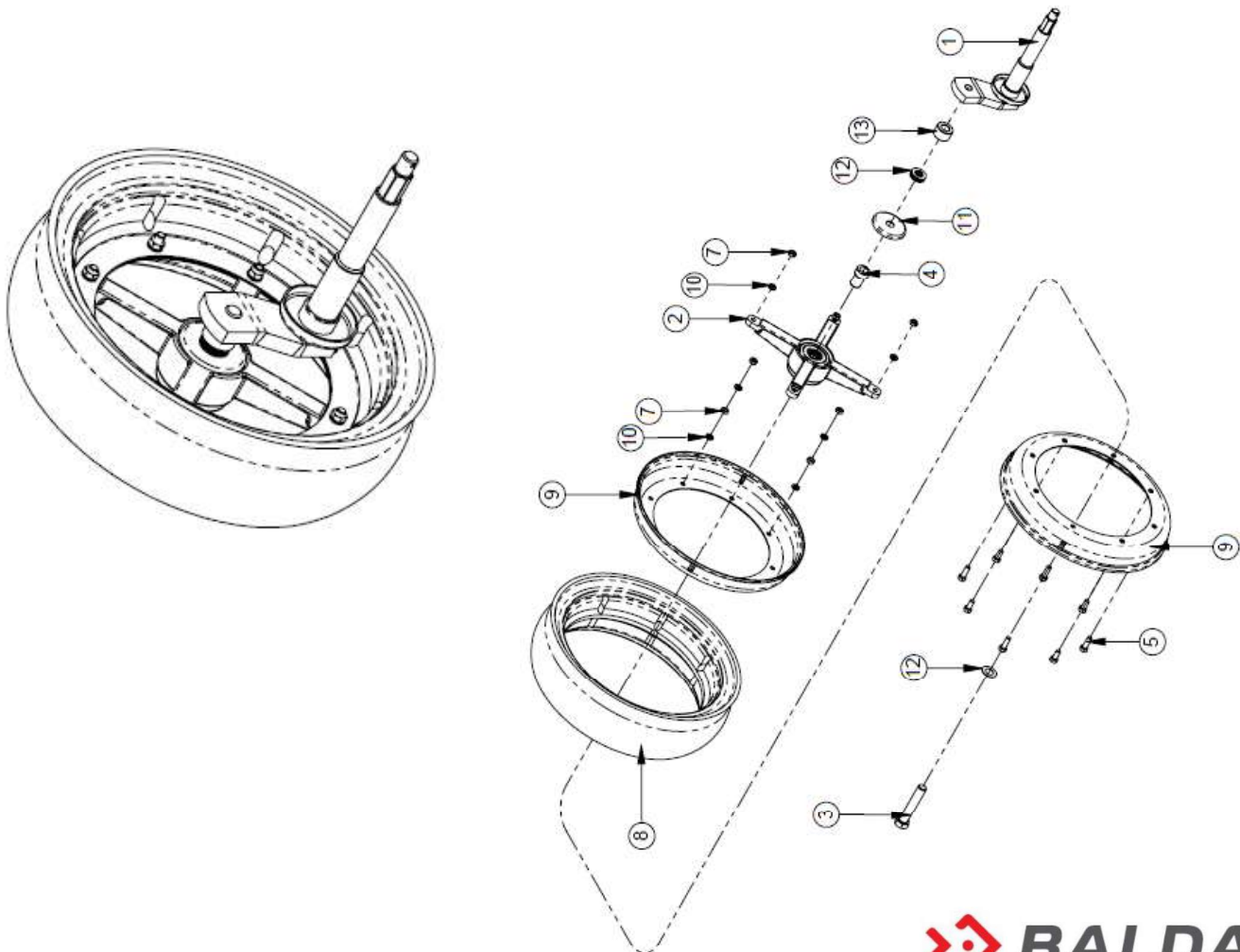

Depth Wheel Hub

Part Number: 5204010486-0

Item No.	Qty	Part No	Description
1	1	BAL52040104828	DEPTH WHEEL HUB SB2019
2	1	BAL60203500524	BEARING 6204 DW HUB SD & SB SERIES
3	1	BAL60203502962	SEAL M25X47X7 DW HUB SB2013-19
4	1	BAL60200110539	CIRCLIP IC047 DW HUB SB2013-19

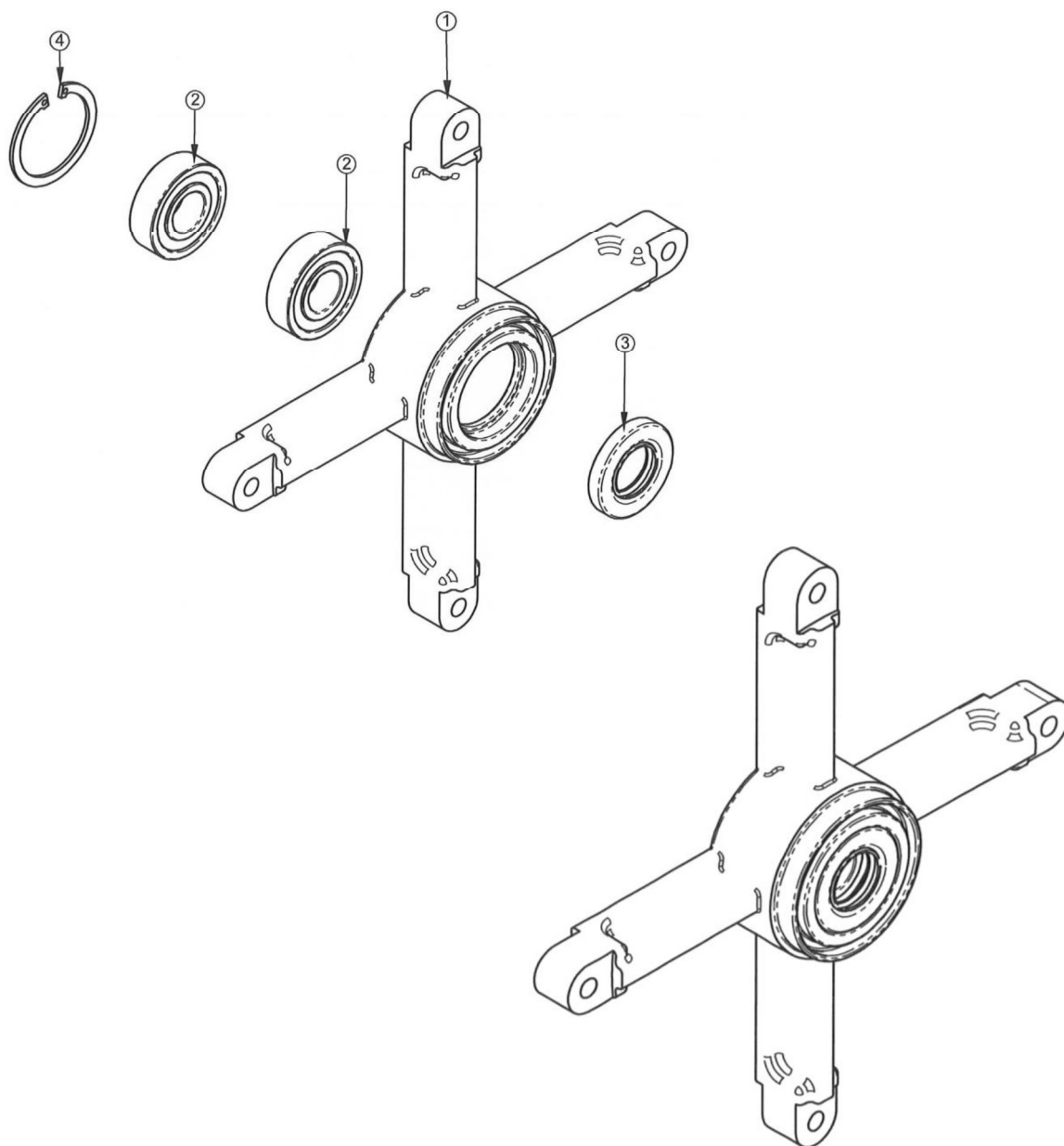

Depth Adjuster Left Hand

Part Number: 54840101471

Item No	Qty	Part No	Description
1	1	BAL60203105021	ROLL PIN 5X24MM
2	1	BAL60203104700	ROLL PIN 3X24MM
3	1	BAL54320105059	PIN DEPTH ADJUSTER SB2013-19
4	1	BAL60200110130	O-RING 2-113 DEPTH ADJ PIN
5	1	BAL53920100020	DEPTH ADJUSTER CAP SD & SB SERIES
6	1	BAL60202502337	SPRING DEPTH ADJ SD & SB SERIES 168 X20X34
7	1	BAL60201301001	GREASE NIPPLE UNF 1/4"
8	1	BAL60203107547	NUT BSW 1/2"
9	1	BAL60203100518	BOLT BSW 1/2"X1-1/4" DEPTH ADJ SB2013-19

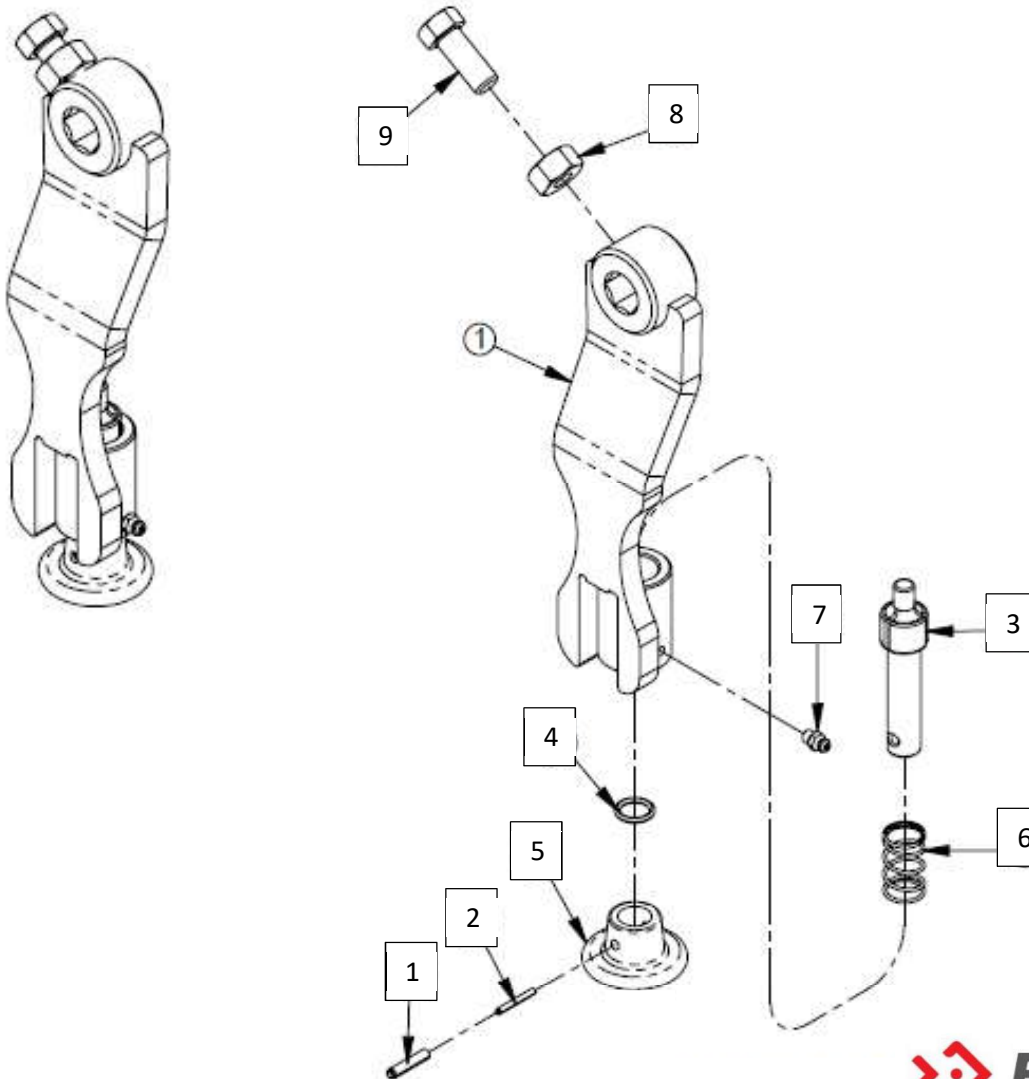

Depth Adjuster Right Hand

Part Number: 5484010150-1

Item No	Qty	Part No	Description
1	1	BAL60203105021	ROLL PIN 5X24MM
2	1	BAL60203104700	ROLL PIN 3X24MM
3	1	BAL54320105059	PIN DEPTH ADJUSTER SB2013-19
4	1	BAL60200110130	O-RING 2-113 DEPTH ADJ PIN
5	1	BAL53920100020	DEPTH ADJUSTER CAP SD & SB SERIES
6	1	BAL60202502337	SPRING DEPTH ADJ SD & SB SERIES 168 X20X34
7	1	BAL60201301001	GREASE NIPPLE UNF 1/4"
8	1	BAL60203107547	NUT BSW 1/2"
9	1	BAL60203100518	BOLT BSW 1/2"X1-1/4" DEPTH ADJ SB2013-19

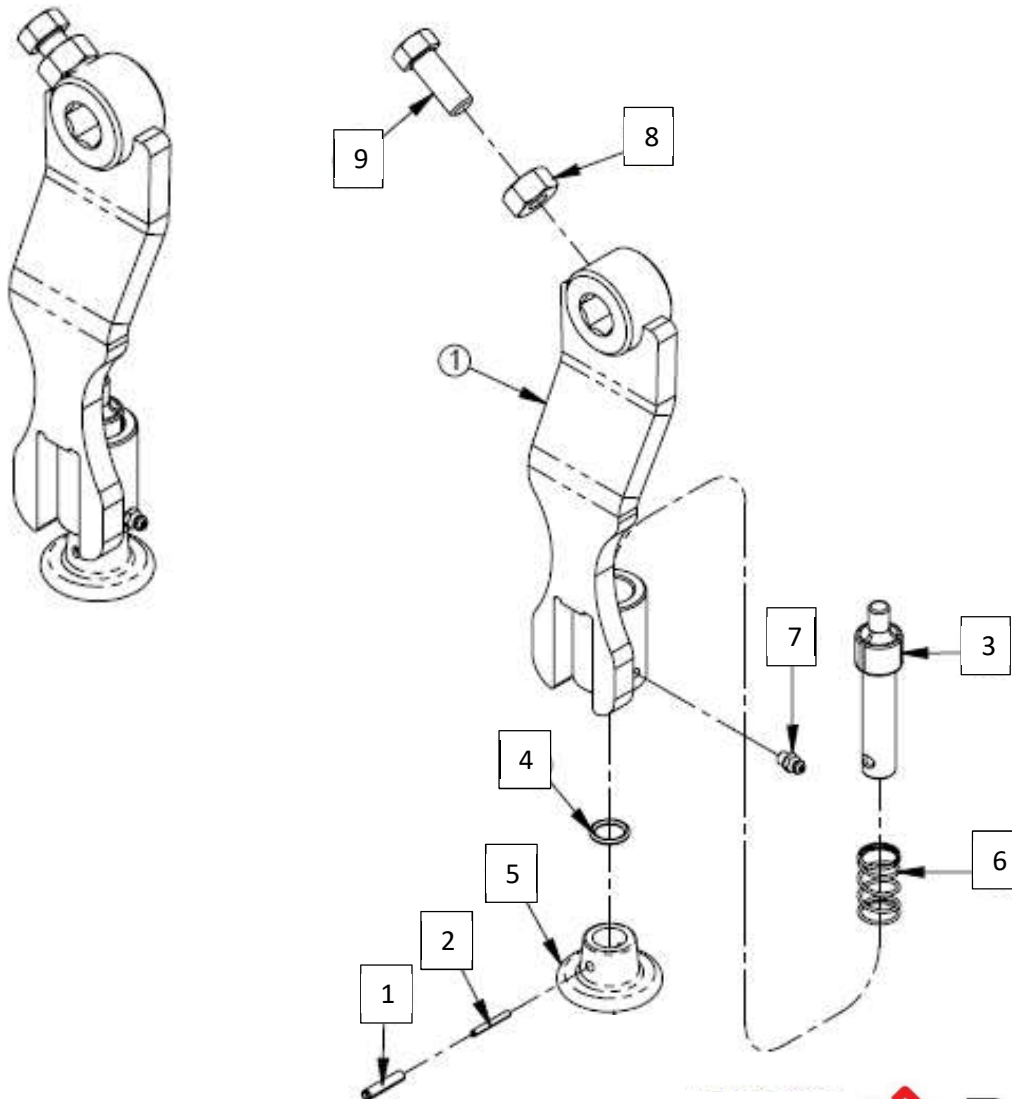

Cover Wheel Arm Left Hand

Part Number: 5530015296-0

Item No	Qty	Part No	Description
1	1	BAL55300152979	COVER WHEEL ARM LH SB2013-19
2	1	BAL60203509297	BEARING 5206 CW ARM SB2013-19
3	1	BAL60203509270	BEARING 5203KYY2 CW ARM SB2013-19
4	1	BAL60200103338	CIRCLIP IC062 CW ARM SB2013-19
5	1	BAL60200102889	CIRCLIP IC040 CW ARM SB2013-19

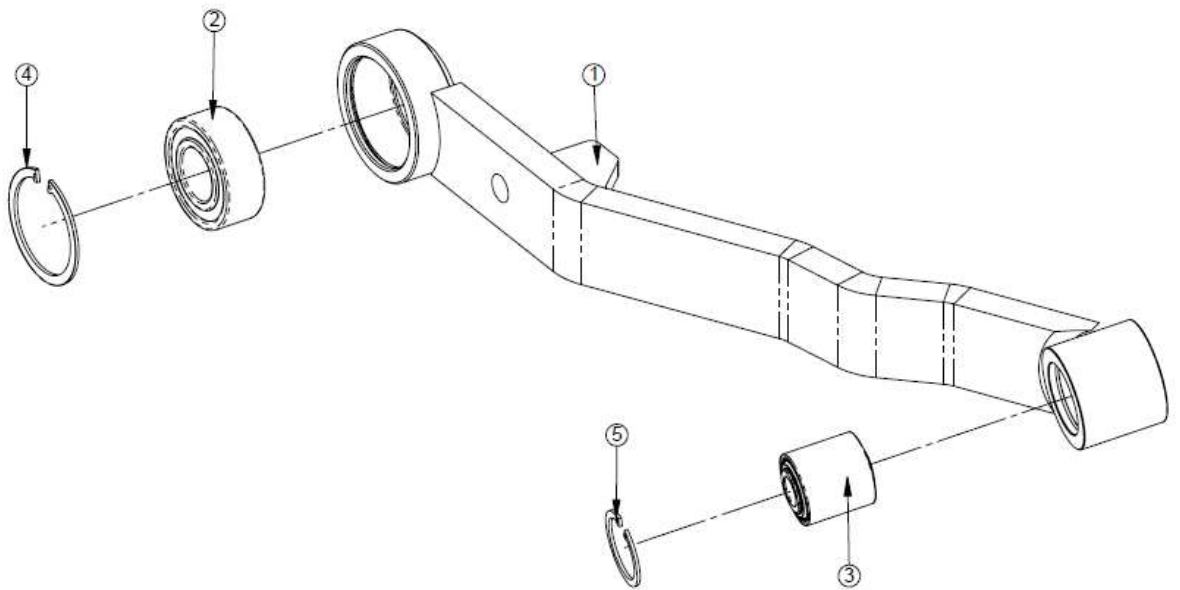
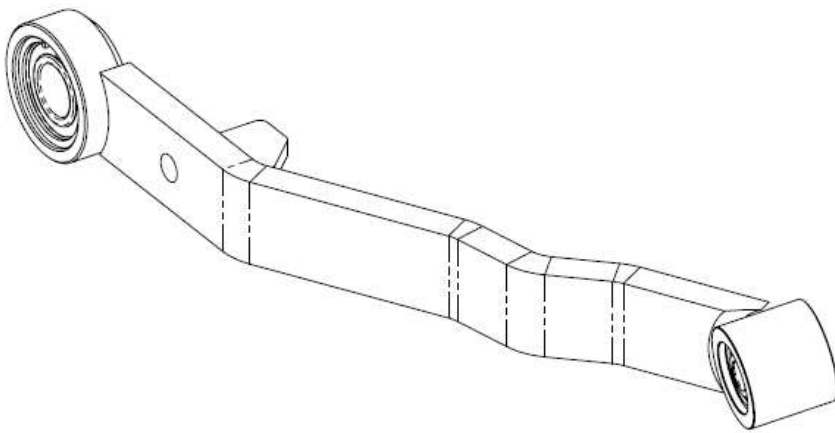

Cover Wheel Arm Right Hand

Part Number: 5530015290-1

Item No	Qty	Part No	Description
1	1	BAL55300152910	COVER WHEEL ARM RH SB2013-19
2	1	BAL60203509297	BEARING 5206 CW ARM SB2013-19
3	1	BAL60203509270	BEARING 5203KYY2 CW ARM SB2013-19
4	1	BAL60200103338	CIRCLIP IC062 CW ARM SB2013-19
5	1	BAL60200102889	CIRCLIP IC040 CW ARM SB2013-19

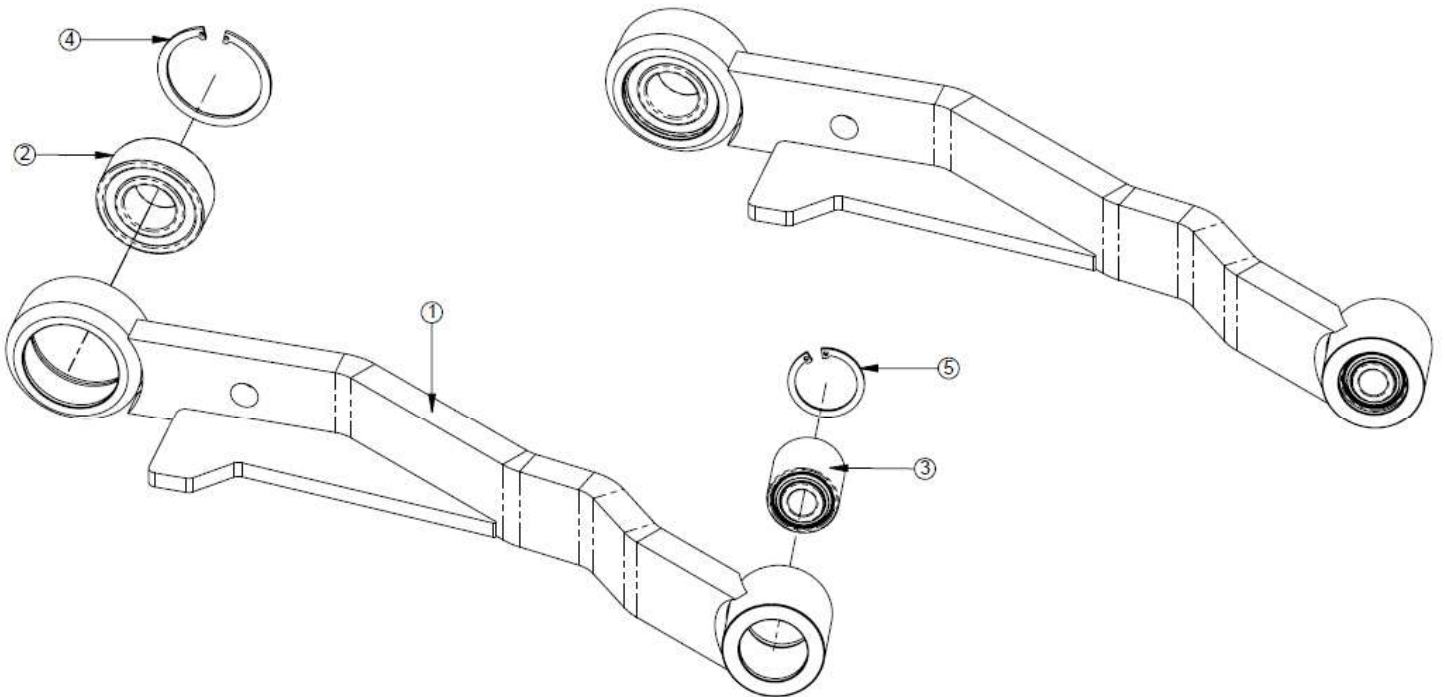

Cover Wheel Complete

Part Number: 5288010062-9

Item No	Qty	Part No	Description
1	1	BAL52880100639	COVER WHEEL CAST & SHAFT SB2013-19
2	7	BAL50240103165	SPACER WASHER CW AXLE SB2013-19
3	1	BAL60200104121	SPRING WASHER 5/8
4	1	BAL60203107610	NUT NYLOC UNF 5/8" ALT NFNN58

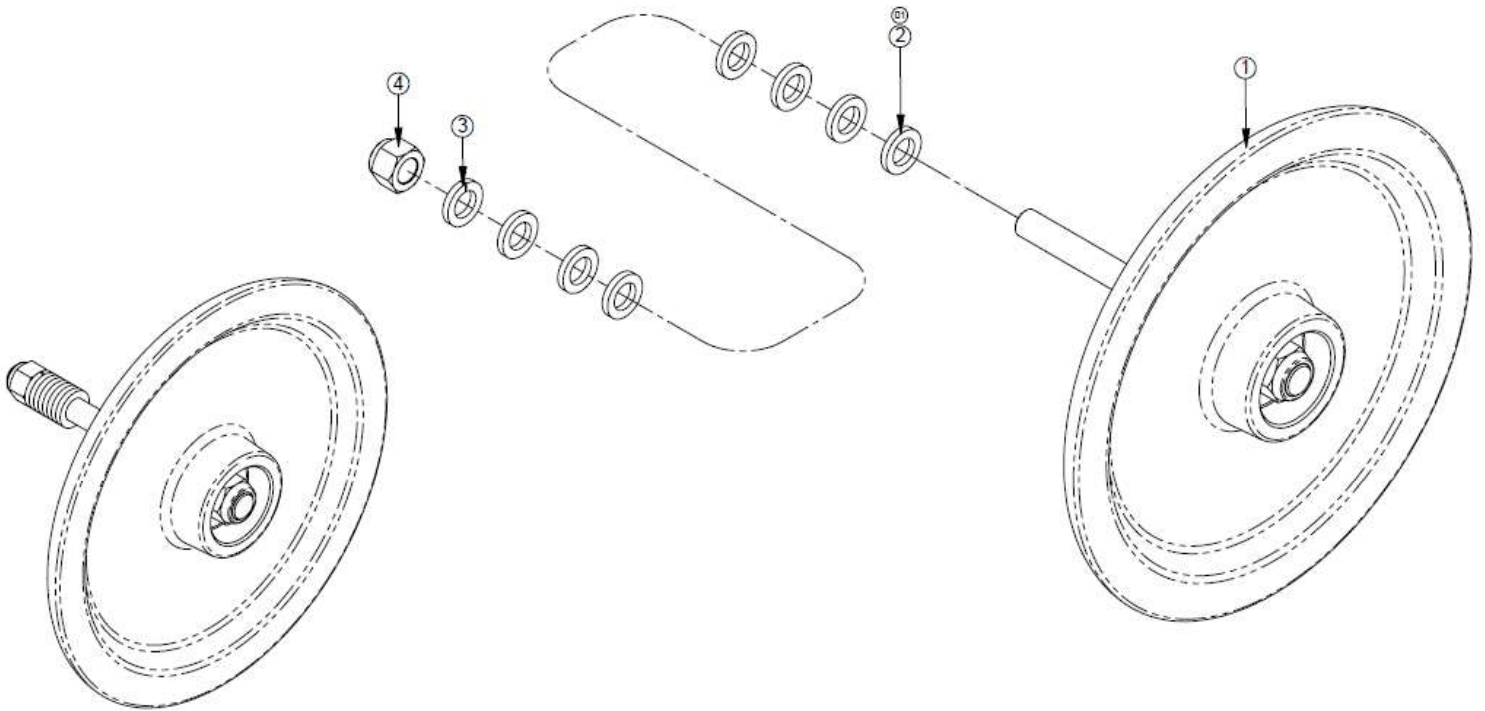

Cover Wheel Shaft

Part Number: 5232011538-8

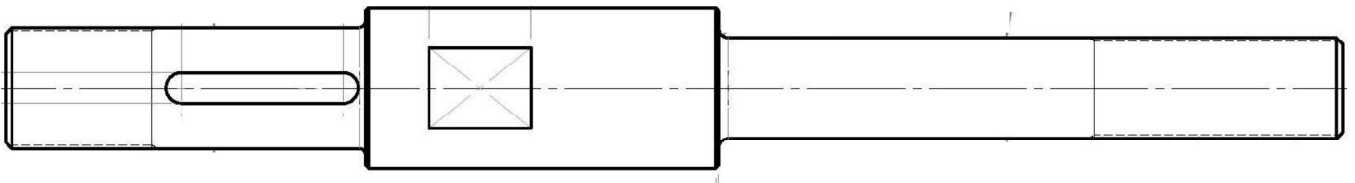

Press Wheel Arm Left Hand

Part Number: 5530015288-0

Item No	Qty	Part No	Description
1	1	BAL55300152898	PRESS WHEEL ARM LH SB2013-19
2	1	BAL55300152898	BEARING 5205 2NSL PW ARM SB2013-19
3	1	BAL60200102919	CIRCLIP IC-050 PW ARM SB2013-19

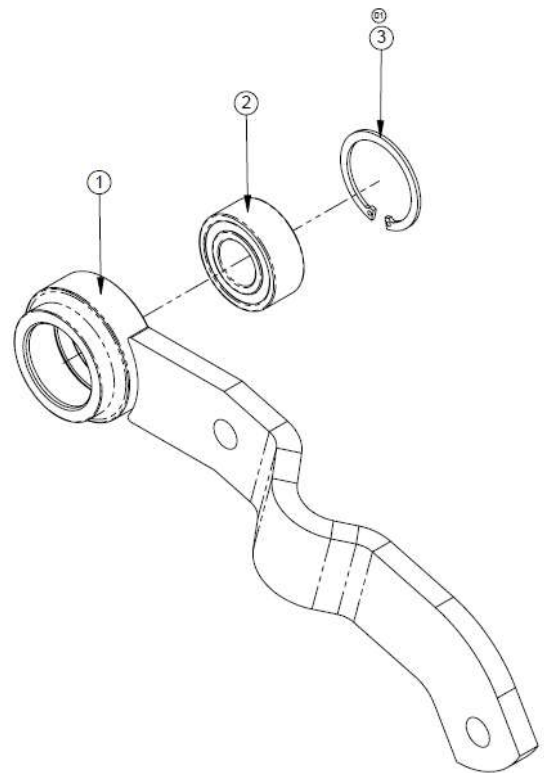
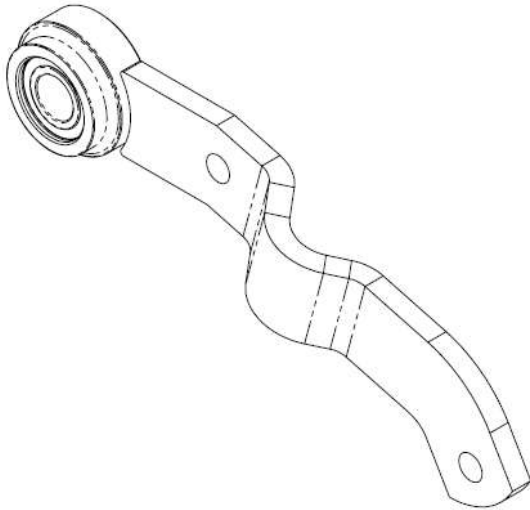

Press Wheel Arm Right Hand

Part Number: 5530015295-2

Item No	Qty	Part No	Description
1	1	BAL55300152936	PRESS WHEEL ARM RH SB2013-19
2	1	BAL60203509289	BEARING 5205 2NSL PW ARM SB2013-19
3	1	BAL60200102919	CIRCLIP IC-050 PW ARM SB2013-19

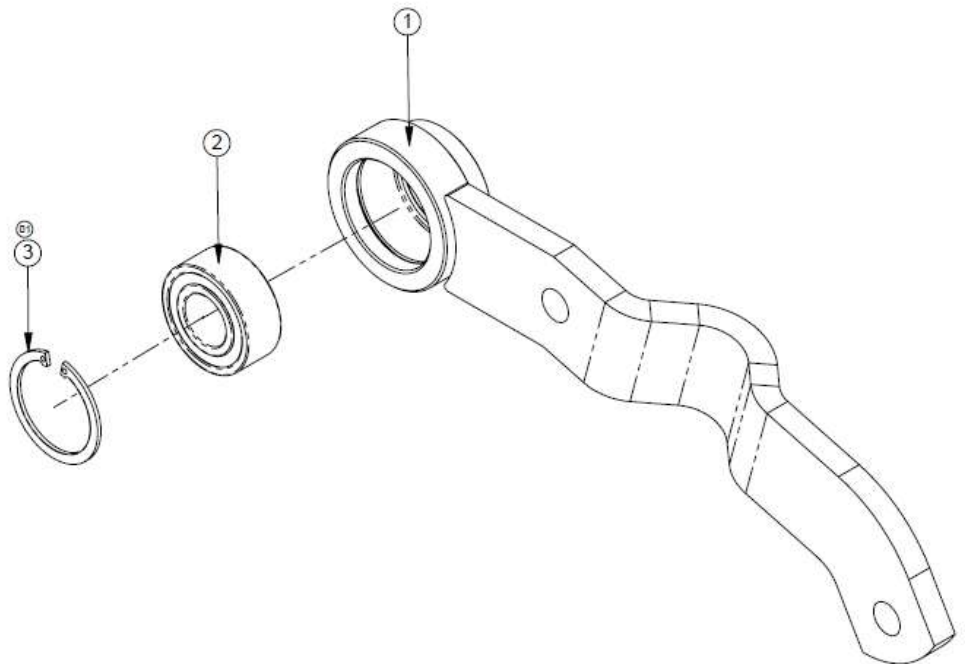
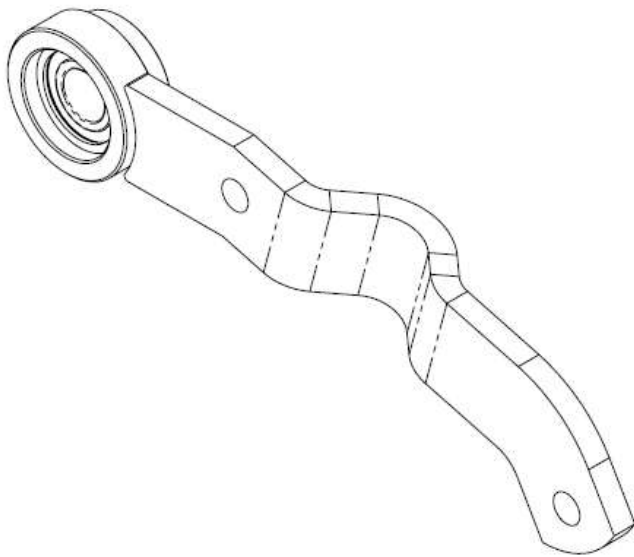

Buco Hard V Press Wheel

Part Number: BUC10020

Item No	Qty	Part No	Description
1	1	BUC10020	PRESS WHEEL COMP W-SOLID V TYRE
2	2	BUCPWHUB	PRESS WHEEL 5203 HUB SUIT BUCO
3	1	BUC10020TYRE	PRESS WHEEL TYRE SOLID V
4	1	5203KYY2	BEARING 5203 KYY2
5	2	BUCPWRIM	PRESS WHEEL RIM TO SUIT 10020



1



2



3



4



5

Cast Roll Bar Bearing

Part Number: SMCRCOMP

Item No	Qty	Part No	Description
1	2	SMCRBBOLT475	BOLT 22X475MM ROLL BAR BRG N.F
2	1	CN163	GREASE NIPPLE 6 X 1 X 180
3	2	SMCRBBOUTER	ROLL BAR BEARING OUTER CAST
4	1	SMCRBBCENT	ROLL BAR BEARING CENTRE
5	1	SMCRBBCLAMP90	ROLL BAR BEARING SPACER 90MM
6	1	SMCRBBCLAMP60	ROLL BAR BEARING CLAMP 60MM
7	2	SWM22	WASHER SPRING 22MM
8	2	MCN22	NUT M22

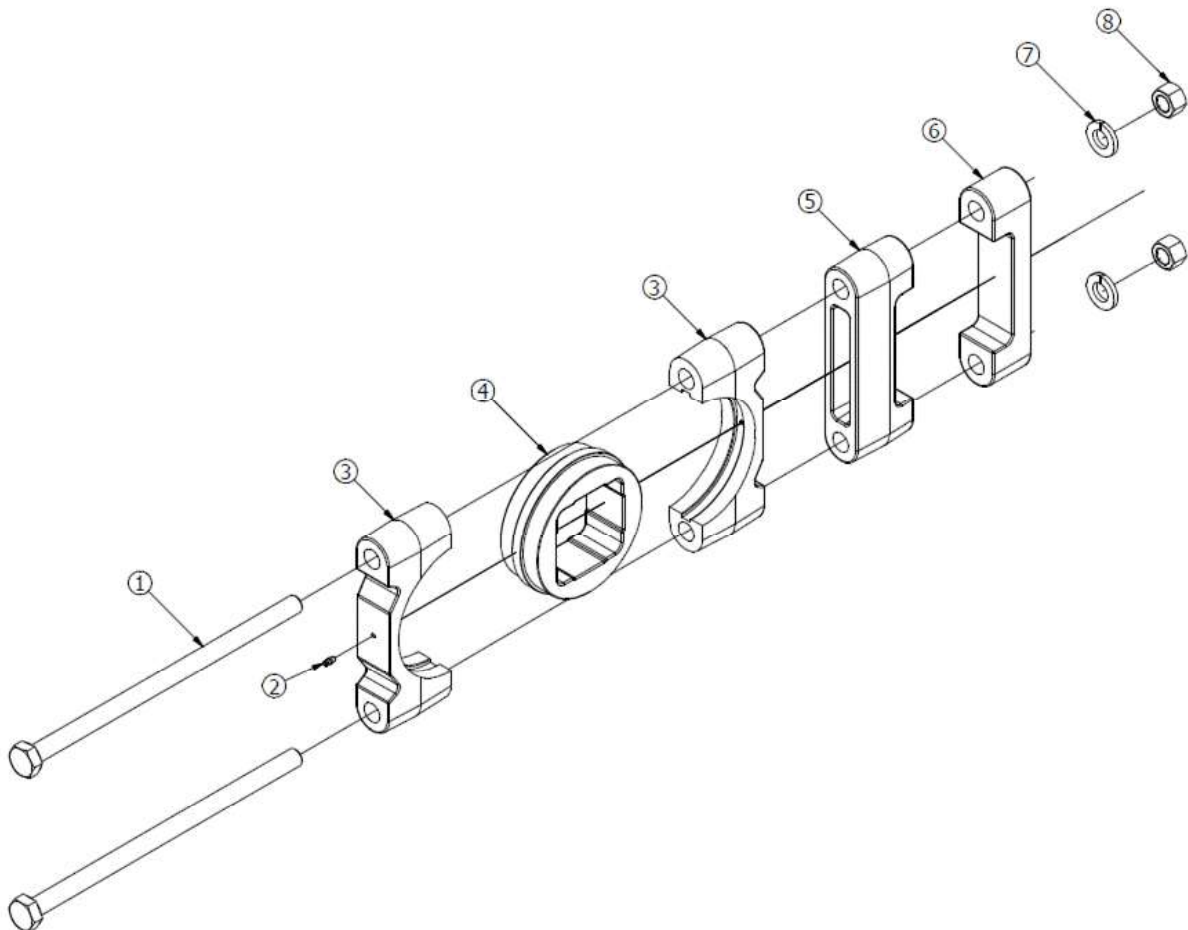

Hydraulic Cylinders



Roll Bar Cylinder: NA30A08



Wing Fold Cylinder: NA35B24



Wing Fold Seal Kit: NAK350-R17

Roll Bar Seal Kit: NAK300-R15

75 Series Stub Axle Assembly

Part Number: 034.491.010

Item No	Qty	Part No	Description
1	1	034.491.020	Stub Axle 75 Round (K1045) x 472 LG
2	1	920.000.765	Triple Lip Seal 90 x 125 x 12mm
3	1	920.000.803	Inner Bearing 32213
4	1	920.000.802	Outer Bearing 32210
5	1	033.131.040	Dust Cap
6	1	920.001.220	Grease Nipple
7	1	920.000.972	Split Pin 60 x 6mm
8	3	920.000.893	Socket Head Cap Screw M8 x 30
9	3	920.001.887	M8 Rib Lock Washer
10	1	920.001.565	Slotted Nut M39 x 2
11	1	920.001.317	Wear Ring
12	1	033.158.030	Seal Ring
13	6	170.057.010	Wheel Nut M18 x 1.5
14	6	170.056.010	Wheel Stud M18 x 1.5
15	1	033.131.080	Hub M/C, Drilled & Studded

